



## welcome to the HP Pro Scanner

### HP Pro Scanner

→ [how do I...?](#)

→ [the problem is...](#)

→ [alphabetical index](#)

This help system will present all you need to know to use your HP Pro Scanner.

Information is organized in three major categories; use the navigation block on the left side of each topic to select one.

See "[Getting Started](#)" for instructions on setting up your system before making your first copy.

See also "[how do I optimize for color accuracy](#)" for instructions on ensuring the best color quality in your copies.

### Getting Started

Contains the steps necessary for setting up the system before making your first copy. Includes instructions for printer setup, preliminary maintenance and media profile creation.

[getting started with your HP Pro Scanner...](#)

### how do I...?

...helps you carry out procedures, like loading media, making copies, or maintaining your scanner.

[...how do I...?](#)

### the problem is...

...helps you solve problems that may occur while copying/scanning.

[...the problem is...](#)

There is also an alphabetical index, accessible from the navigation block, to help you find topics quickly.

You can also refer to the Quick Reference Guide that came with your scanner for basic routine procedures.

For user information on your HP large format printer refer to the documentation that came with the printer.



[→ printing instructions](#)

[→ legal information](#)

© Copyright 2012, 2015 HP Development Company, L.P



## how do I...? (some step-by-step procedures)

### HP Pro Scanner

- [how do I...?](#)
- [the problem is...](#)
- [alphabetical index](#)

#### [How do I make copies?](#)

(quick copying, selecting templates, input/output size, scaling, select media profile, quality, batch, save a duplicate...)

#### [How do I scan to file?](#)

(general steps, original templates, input size, resize, scaling, resolution, quality, batch, scan to folder, scan to email, multipage files ...)

#### [How do I print from files?](#)

(print from files, set up and maintain a print list, delete files from computer...)

#### [How do I manage files on the system?](#)

(browse files, move files, rename files, delete files, copy files)

#### [How do I use copy options and tools?](#)

(previewing, copy number, layout, alignment, print queue, margins, rotate, page order, output destination...)

#### [How do I customize my copy tools?](#)

(creating original templates, size presets, creating media profiles...)

#### [How do I maintain/recover/update my system?](#)

(maintenance, calibration, replacing parts, recovery, software update, shut down, see scanner status, create debugging files (troubleshooting) ...)

#### [How do I set up the system?](#)

(scanner setup options, preferences, interface options, accounting, network connect, printer install, date and time, language...)

#### [How do I scan/copy thick media?](#)

(copy/scan thick media, change insertion slot height)

### how do I make copies?

Select a topic...

[...make copies](#)

[...select an original template](#)

[...set the input size](#)

[...set the output size](#)

[...select a media profile](#)

[...set the copy quality](#)

[...optimize for color accuracy](#)

[...set a scale factor](#)

[...set the printer media width](#)

[...copy whole batches of originals](#)

[...collate copies](#)

[...how do I save \(to file\) a duplicate of my copy?](#)

## how do I scan to file?

Select a topic...

[...scan to a file](#)

[...select an original template](#)

[...set scan resolution](#)

[...set scan quality settings](#)

[...set the original's size \(input size\)](#)

[...use the Resize option to determine output size](#)

[...set the output size](#)

[...set a scale factor](#)

[...scan to and access a network folder](#)

[...scan to an FTP server](#)

[...scan-to-file whole batches of originals](#)

[...save \(to file\) a duplicate of my copy](#)

[...manage image files on my system](#)

[...scan to email...](#)

[...set for automatic naming of files...](#)

[...scan multiple pages into a single file...](#)

## how do I print from files?

Select a topic...

[...print from files](#)

[... set print from file quality](#)

[...set up a print list](#)

[...maintain the print list](#)

## how do manage files on the system?

Select a topic...

[...manage image files on my system](#)

[...access a network folder...](#)

[...browse, preview and select files in the file management dialog](#)

[...Copy image files...](#)

[...Move image files...](#)

[...Delete image files...](#)

[...Rename image files...](#)

[...create a new file folder...](#)

[...Add image files to the print list...](#)

## how do I use copy options and tools?

Select a topic...

[...use the previewing tools](#)

[...set the number of copies](#)

[...print on multiple printers](#)

[...use nesting](#)

[...use paneling](#)

[...set paneling and tiling options and assemble panels](#)

[...automatically align the image](#)

[...view the print queue](#)

[...set the output margins](#)

[... clip contents by printer's margins](#)

[...input in portrait and output in landscape?](#)

[...rotate the output 90 dregrees?](#)

[...set page order?](#)

[...set output destination?](#)

[...set folding options?](#)

## how do I customize my copy tools?

Select a topic...

[...define an original template](#)

[...make type of original settings](#)

[...create a custom scale size](#)

[...create a custom paper size preset \(Input size and Output size\)](#)

[...create a media profile](#)

## how do I maintain/recover/update my system?

Select a topic...

[...maintenance procedures](#)

[...view scanner messages](#)

[... replace scanner parts](#)

[...replace glass plate- HP SD Pro Scanner](#)

[...replace glass plate - HP HD Pro Scanner](#)

[...replace the white background platen](#)

[...replace the scanner lamp](#)

[...set the scanner system power up/down timer](#)

[...recover the system or update the software](#)

[...shut down the system](#)

[...view information about the scanner](#)

[...create and retrieve data files for support/debugging](#)

[...print help pages](#)

## how do I set up the system?

Select a topic...

[...set preferences](#)

[...set user interface options](#)

[...set paper load - Auto or Manual](#)

[...set media offset](#)

[...set extended thickness correction settings](#)

[...change the default Administrator password](#)

[...connect to a network](#)

[...make network settings](#)

[...access shared files from another computer](#)

[...automatic power up/down](#)

[...use accounting](#)

[...create/delete/disable an account](#)

[...select/activate an existing account](#)

[...change the interface language](#)

[...install printer and printer drivers](#)

[...set date and time](#)

[...enable storage of network connections](#)

## how do I copy and scan thick media?

Select a topic...

[...copy/scan thick media](#)

[...change insertion slot height \(thick media scanning\)](#)





→ [printing instructions](#)

→ [legal information](#)

© Copyright 2012, 2015 HP Development Company, L.P



## HP Pro Scanner

→ [how do I...?](#)

→ [the problem is...](#)

→ [alphabetical index](#)

## how do I... maintenance procedures

Maintenance procedures should all be performed in a single maintenance session, starting with [Cleaning the scan area](#) and ending with [Camera alignment and calibration](#).

It is recommended to perform the scanner maintenance procedures at least once per month.

### cleaning the scan area

1. Turn the scanner power off and disconnect the scanner power cable.

2. Open the scanner cover.

- Press the two release buttons to disengage the locks and open the lid. The release buttons are found near the insertion slot on each side of the scanning area lid, or at the back of the lid depending on the scanner model.
- The scanning area is now exposed for cleaning.

3. Gently wipe the **glass plate**

Clean the glass with a lint-free cloth and a mild, streak-free, glass cleaner.

**Caution:** do not use abrasives, acetone, benzene, or fluids that contain these chemicals. Do not spray liquids directly onto the scanner's glass plate or anywhere else in the scanner.

**Caution:** the lifespan of the glass plate depends on the paper types that pass across it. Abrasive papers such as mylar may cause premature deterioration, in which case the replacement of the plate is the customer's responsibility.

4. Dry the glass completely using a separate clean, dry lint-free cloth like the one provided with the maintenance kit.

5. Clean the **white background platen/white rollers**

*On scanners with white pressure-platen* - white background platen (white metal area) is fixed in the scanning area lid. Hold the lid open as you clean. Warning - do not attempt to remove the white background platen for cleaning it. Removing the white background platen is only necessary when [replacing it](#).

*On scanners with white pressure rollers* - the white rollers are at the bottom between the transport rollers.

Wipe the white platen/rollers with a lint-free cloth and a mild, streak-free, glass cleaner. Apply the cleaner to the cloth and first and then wipe the white area.

6. Clean the **upper and lower transport rollers** and surrounding area.

Wipe the rollers with a lint-free cloth and a mild, streak-free, glass cleaner.

**Caution: do not use abrasives, acetone, benzene or fluids that contain these chemicals.**

7. Dry the white background platen, transport rollers and surrounding area fully using a separate clean, dry lint-free cloth.

8. Clean also the **scanner feed surface** so dirt and dust are not dragged into the scan area with the original.

9. Close the scanner cover. The locks will reengage.

You can now calibrate the scanner.

### **camera calibration (including camera alignment)**

**Before you calibrate, make sure that you have cleaned the scan area. An unclean scanning area will give you imprecise calibration results. Camera calibration is a fully automatic process that you only need to activate through the wizard and then leave to run on its own.**

1. Connect the scanner power cable.

2. Power ON the scanner.

3. The scanner should be warm - apply only for the HP HD Pro Scanner.

Make sure that the scanner has been turned on for at least one hour prior to calibration. Slight light intensity changes and camera shifting can occur just after turning the scanner on and the warm-up time will ensure that light conditions and camera heights have stabilized.

4. Select the Setup tab.

5. Press  and select Scanning

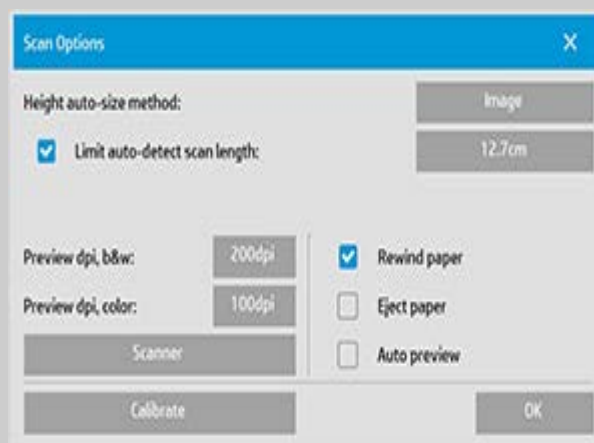

6. Press the *Calibrate* button to start the Calibration wizard.



Select either **Camera Alignment** or **Full Calibration**.

- Camera Alignment will align horizontal capture for correct image stitching.
- Full Calibration will perform Camera Alignment, B&W Calibration, and Color calibration in the same session.

7. Insert the Calibration Sheet that came with your system.

Align the sheet's midpoint arrow with the scanner's midpoint arrow and feed the sheet into the scanner.

8. When calibration is completed, remove the Calibration Sheet from the scanner and return it to its protective cover or tube. Store the calibration sheet in a dry place and out of direct light.



[→ printing instructions](#)

[→ legal information](#)

© Copyright 2012, 2015 HP Development Company, L.P



## HP Pro Scanner

→ [how do I...?](#)

→ [the problem is...](#)

→ [alphabetical index](#)

## how do I make copies?

Follow the instructions below for making copies. In many cases, the basic options will already be set and you won't have to change them.

### to make copies...

1. Load the original - Place the document with the intended top edge forward in the scanner insertion slot.
2. Slide the document gently into the insertion slot until you feel it pulled into the start position.
3. In the Copy tab, select Color or B&W (black and white) copying — this determines the Type of original.
4. Select your [Type of original template](#).
5. Set the [Lightness](#) level of your copy.
6. You can set copy quality through the Quality button. [See instructions](#).
7. Set the [Input size](#). Usually this will be equal to the size of your original. You can let the scanner detect the document's size.
8. Set the intended [Output size](#) of your copy.
9. Select your [Paper type](#).
10. If Copies is set more than one then [Collate](#) will be possible to set.



For making one-to-one copies, this will be the size of your original. You can also use [Scale](#) to determine the copy's size.

11. Press the Copy button.



You can preview the image before printing. The preview will give you a "What You See Is What You Get" (WYSIWYG) picture of your copy. Press the Preview button to load a preview of your copy.



You can use the Stop button if you need to cancel/abort as running copy process. You can also use it to cancel a preview of an image file while it is being loaded.



Press the Reset button to clear your own settings and reset the application to all of the scanner software's default values.





## how do I change the insertion slot height (thick media scanning)?

### HP Pro Scanner

→ [how do I...?](#)

→ [the problem is...](#)

→ [alphabetical index](#)

**NOTE:** Adjustment for thickness, and the following instructions apply only with scanners - HP HD Pro Scanner

You may need to scan documents and drawings printed or pasted on thick media such as cardboard, foamboards, gatorboards etc. To do so, you will need to fit the insertion slot to the thickness of your original. On some scanner models, this can be done by raising the pressure-platen to the exact correct height.

If your scanner supports Automatic Thickness Adjustment Control (ATAC) its panel will have Up and Down keys as illustrated below.



1. Press the ATAC Up-key to raise the pressure platen



2. Press the ATAC Down-key to lower the pressure platen and match to the thick original

You use the keys to raise and lower the pressure-platen and thus can change the insertion slot size (pressure-platen height) on your scanner in the range from 2mm to 15 mm (up to 0.6"). Originals up to 2mm thick should be scanned with the pressure all the way down (normal position). Thicker originals will require you use the ATAC functionality.



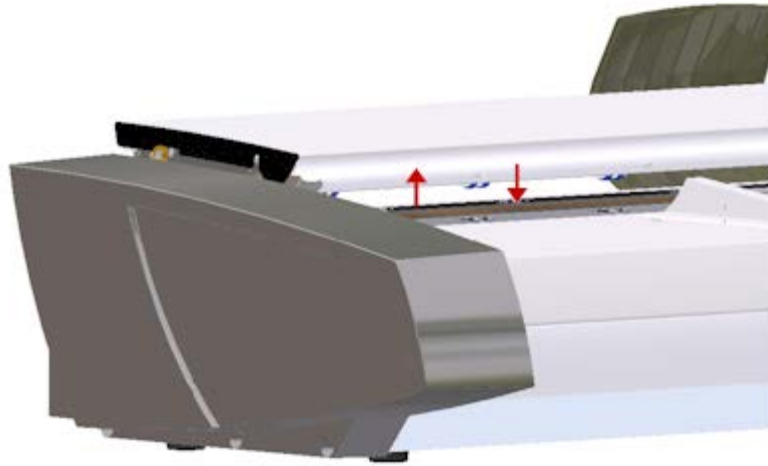

When the insertion slot height is not in the Normal position, the following warning is displayed below the preview window on your touch screen:

*Paper Guide in Extended Position*

**to adjust the insertion slot for thick media...**

1. Press and hold down the ATAC Up-key on your operator's panel to raise the pressure platen and enlarge the insertion slot until there is room to insert the thick original.
2. The *ATAC Indicator* blinks yellow indicating the scanner is in ATAC mode.
3. Insert the thick original evenly for a straight scan path.
4. Press and hold the ATAC Down-Key to lower the pressure-platen until the pressure-platen rests on the original and stops on its own.
5. The ATAC indicator will stop blinking and remain yellow when the pressure-platen is positioned correctly and is ready for thick media scanning.
6. When finished scanning, and you have ejected the thick original, press and hold the ATAC Down-Key to return the pressure-platen to its normal position. The ATAC indicator LED will turn off.



[→ printing instructions](#)

[→ legal information](#)

© Copyright 2012, 2015 HP Development Company, L.P



## HP Pro Scanner

→ [how do I...?](#)

→ [the problem is...](#)

→ [alphabetical index](#)

## how do I copy/scan thick media?

Follow the guidelines below for problem free scanning of thick media.

First you must adjust the insertion slot height to accommodate your thick media. See:

...[how do I change the insertion slot height?](#)

**NOTE:** Adjustment for thickness, and the following instructions apply only with scanners - HP HD Pro Scanner

Scanning thick media will require enlarging the insertion slot and this can affect the scanner's automatic control of border lines between the cameras, called Stitching. Instructions for compensating for this follow below.

## to copy thick media..

1. Change the insertion slot height to fit the original as described in ...[how do I change the insertion slot height?](#)
2. Make a test scan.

Bulky thick media need to be supported with both hands both into and out of the scanner.

Stitching errors will be easiest to see on an image with one or more clear diagonal lines.

Normally, only stiff media will affect stitching. Flexible media will usually be stitched correctly regardless of thickness.

If the lines seem uneven, do the following:

3. Select the Setup tab.
4. Select  > Scanning.

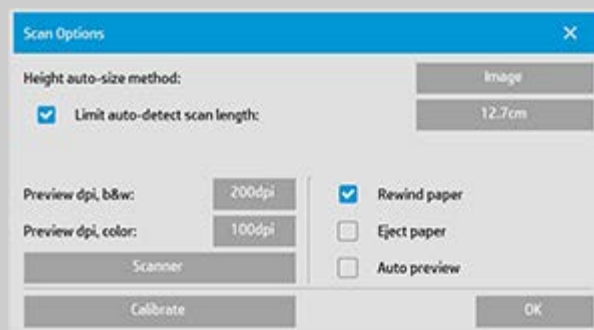

5. Select the Scanner button.

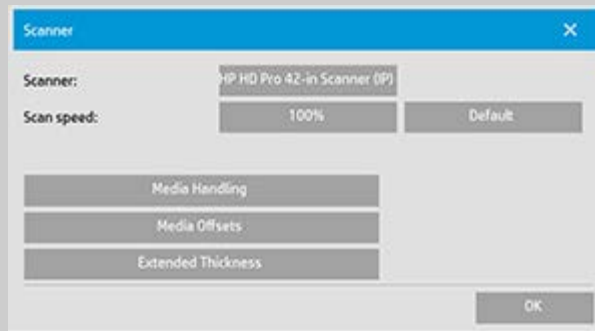

6. Select the Extended Thickness button.
7. Check the box labeled Use extended thickness paper handling.
8. Change the value for each of the scanner's cameras — normally, only positive values should be used.
9. Make test scans and readjust the values until you are satisfied that the lines are stitched correctly.
10. Click OK to accept your settings.
11. Repeat the above steps until you are satisfied with the results.





## how do I select an original template?

### HP Pro Scanner

→ [how do I...?](#)

→ [the problem is...](#)

→ [alphabetical index](#)

The Type of Original template defines the original you wish to input. Type of Original templates are used for both copy and scan-to-file jobs (Copy tab and Scan tab).

### to select a type of original template...

1. Select B&W or Color Your selection will determine the Type of Original templates displayed in the next steps.
2. Press the Type of original button.
3. Select from the list a Type of Original template that best describes your current input. The Type of Original templates displayed depend on if you selected Color or B&W in step 1.

B&W  Color



See also:

...[to define an original template...](#)

...[how do I make type of original template settings](#)





## HP Pro Scanner

→ [how do I...?](#)

→ [the problem is...](#)

→ [alphabetical index](#)

## how do I define an original template?

Adjustments to a Type of Original template's settings will normally be discarded when you close the program. You can however choose to save them as a new custom Type of Original template. Type of original templates apply for both copying (Copy Tab) and scan to file (Scan tab).

### to define an original template...

1. Press the Copy tab or the Scan tab.
2. Set the copy mode to Color or B&W.

3. Press the Type of original button to open the Type of original (template) menu.



4. Use the Tool button to open the Type of original Setup dialog.



If a preview of the copy is currently loaded, the Type of original Setup dialog will start up with the Image Filter Preview and split screen for

on-line assessment of your change's effects.

5. After having made your settings and ensuring that they work well with the current original, press the New button.

For information on template settings, see:

...[how do I make original template settings?](#)

The top preview panel illustrates changes to the image after modifying your template settings.

6. Enter the name for your new template. Select a name that represents the type of copy job you are working with, such as "Fruit Photos".
7. Press the Save button to create the new Type of Original template.

Your new Type of Original template will be added to the list of those already available. You can start with one of the predefined Type of Original presets that is closest to your original, save it under a new name and then change it to fit your specific needs. Use the preview to test your settings.

If you have changed your settings for the current Type of Original template pressing the OK button will accept the values but they will only be used for the current copy job. The next time you call up the template, it will have regained its old settings.

8. Press the Save button when you are finished.
9. Press OK to confirm.

See also:

...[how to select a type of original template](#)

...[how do I make original template settings](#)





## HP Pro Scanner

→ [how do I...?](#)

→ [the problem is...](#)

→ [alphabetical index](#)

## how do I set the input size?

### to select the input size...

1. Press the Copy tab if performing a copy job or Scan tab if performing a scan-to-file job.
2. Press the Input size button (Copy tab) or Size button (Scan tab) to open the input size menu.



You can use Auto size detection for input size, standard sizes or custom size presets. Press the dialog's Input size button to display the list of available sizes.

3. Select an input size or use the Tool button to open the Input size setup dialog.

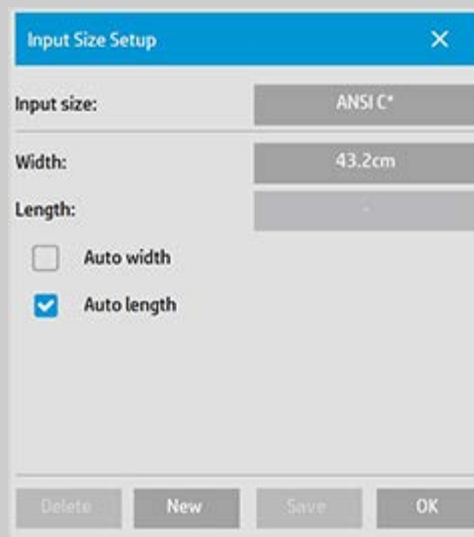



4. To set the input size you can:

- Specify the width and length. The original's width can be read off the ruler at the scanner's insertion slot.
- Select Auto Width and/or Auto Length to let the scanner detect the physical input width and/or length of the inserted document.
- Press the dialog's Input size button to display the list of available sizes.

Both Auto Width and Auto Length can be applied for total input size detection. Automatic size detection works through a prescan of the original and copying thus requires more time than with manual size settings.

5. Press OK to return to the main (Copy or Scan) settings.

You can also save your settings in a new Size Preset. [See how do I create a custom paper size.](#)

You can also use a scale factor to determine the output size. See: [...how do I set a scaling factor](#)

See also:

[...how do I set the output size?](#)





## HP Pro Scanner

→ [how do I...?](#)

→ [the problem is...](#)

→ [alphabetical index](#)

## how do I set the output size?

### to select the output size...

1. If in the Copy tab - Press Output size->Output Size to open the Output size menu. If in the Scan tab, press Resize->Size.



You can use Auto size, standard sizes or custom size presets.

2. Select an output size or use the Tool button to open the Output size setup dialog.

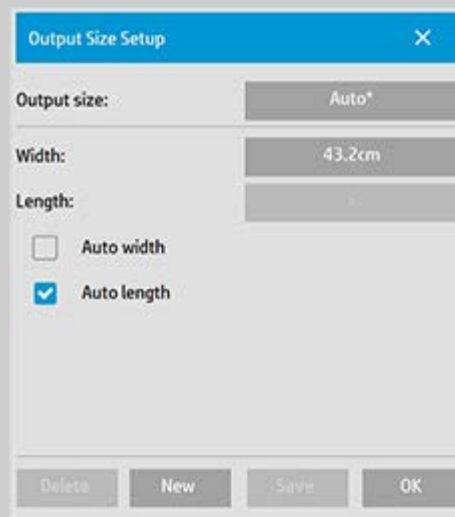

3. To set the output size you can:

- Select Auto if you want the program to take the input size and use it also as the output size for creating a 1:1 copy.
- Select standard sizes from the list as your output size.

- You can create custom sizes and save them as presets. You can specify the Output size by setting the Width and Length. Press the tool button to open the Output size setup dialog.

4. Press OK to return to the Copy tab.

You can also use a scale factor to determine the output size. See:

[...setting a scale factor](#)

See also:

[...how do I set the input size?](#)



→ [printing instructions](#)

→ [legal information](#)

© Copyright 2012, 2015 HP Development Company, L.P



## HP Pro Scanner

→ [how do I...?](#)

→ [the problem is...](#)

→ [alphabetical index](#)

## how do I set a scale factor?

### to scale copies or images with scan-to-file ...

1. After making your input setting: If in the Copy tab press Output size -> Scale. If in the Scan tab, press Resize -> Scale. These actions will display the list of standard or customized scaling factors predefined in your system.
2. Select the Scale value that fits your intentions. A Scale factor of 100% makes a 1:1 duplicate. Below 100% reduces the image and above 100% magnifies it.
3. If you need to define a new scale factor: select the Tool button to open the Scale setup dialog. Here you can manually set a scale factor with the Value button.
4. To save a new scale factor by adding it to the list of predefined scale factors - Press the New button to give the new scale factor a name and the Value button to enter its value. Press the Save button to add it to the list.

*TIP: Make a fast miniature version of your big copy by setting the Scale factor to 25%.*



→ [printing instructions](#)

→ [legal information](#)

© Copyright 2012, 2015 HP Development Company, L.P



## HP Pro Scanner

→ [how do I...?](#)

→ [the problem is...](#)

→ [alphabetical index](#)

## how do I set the number of copies?

### to set the number of copies...

Wide-format copy jobs can be time-consuming. This option allows you to leave the system working overnight or frees you to take care of other tasks.

1. Press the button labeled Copies in the Copy tab if you want to make more than one copy of the loaded original.
2. Enter the number of copies in the edit field.



→ [printing instructions](#)

→ [legal information](#)

© Copyright 2012, 2015 HP Development Company, L.P



## HP Pro Scanner

→ [how do I...?](#)

→ [the problem is...](#)

→ [alphabetical index](#)

## how do I use the previewing tools?

The Preview button loads a fresh preview of the copy each time it is selected.



The image always uses the last settings made and the effects of the settings will be visible in the new preview. This feature allows you to fine-tune your settings as you watch them take effect before committing the copy to print.

how to...

...[display the whole image...](#)

...[zoom in on a specific area...](#)

...[zoom out from a selected area...](#)

...[set one-to-one pixel viewing...](#)

...[resize the paper frame...](#)

...[move the image...](#)

...[position the paper frame...](#)

...[align the image...](#)

### to display the whole image...



You can use the Zoom All tool to view large format originals in the preview window. No matter what zooming level you start from, the Zoom All tool resizes the image so that it exactly fits in the preview window.

### to zoom in on a specific area...



Use the Zoom In tool when you need to view details for making enhancement settings and for aligning. Zooming takes place immediately with the zoom axis in the center of the preview window. This means you may need to move the image to center on a specific area before zooming. This is done with the Move Image tool (see below). If you need to enlarge the image further, then continue to press the Zoom In button until you get the required level of detail in the view.

## to zoom out from a selected area...



The Zoom Out tool decreases the image size in the preview window. If you need to decrease the image further, then continue to press the Zoom Out button until you get the required field of view.

## one-to-one pixel viewing...

1:1

Use the 1:1 tool to view the image with one scanned pixel shown as one screen pixel. Note that the actual copy/scan may show additional details as the preview is a low-resolution view. The preview resolution can be set through Setup Tab >  > Scanning. [Instructions..](#)

## to resize the paper frame...

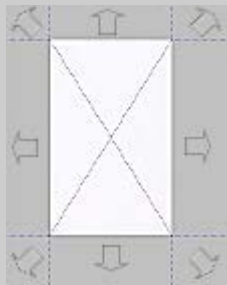

The resize paper frame tool lets you resize the paper frame interactively in the preview window.

When activated, the Resize Paper Frame Tool partitions the areas around the paper frame into sections. When a section is touched, the closest frame side or corner is resized to the new position. You can also drag the edges to resize the frame.

## to move the image...



There are two ways to use the move image tool:

**Dragging:** Dragging anywhere in the image window. Imagine you are gripping hold of the image and dragging it around inside the window.

**Centering:** Touch a point on the screen and that point will then be centered in the preview window. The image shifts so that the point you selected becomes repositioned in the center of the screen. This method is especially useful when zooming in on image details. It lets you pick out important spots and center on them before zooming in.

## to position the paper frame...



There are three ways to use the position paper frame tool:

**Dragging:** Dragging anywhere on the screen. Imagine you are gripping hold of the frame and dragging it around over the image.

**Centering:** Touch a point on the screen and that point becomes the new center for the paper frame. The frame shifts so that it positions itself with the point you selected directly in its center. This method is especially useful when you are making spot test strips for outputting on the printer. It lets you continuously and rapidly reposition the frame on important areas that you want tested.

**Dragging the edges:** This will resize the paper frame and is an alternative to the Resize Paper Frame tool.

## to align the image...

The original may have been inserted slightly off balance and appears crooked in the preview window. Correcting this does not mean you have to reload the original and start again.

Use the perfectly aligned sides of the paper frame as references when realigning.



Press the Align Left tool to tilt the image left.

Press the Align Right tool to tilt the image right.









## how do I set preferences?

### HP Pro Scanner

- [how do I...?](#)
- [the problem is...](#)
- [alphabetical index](#)

### scan and user interface options

1. Press the Setup tab.
2. Press  > Scanning for setting scanner related options.  
Press  > General for setting user interface options.





## HP Pro Scanner

→ [how do I...?](#)

→ [the problem is...](#)

→ [alphabetical index](#)

## how do I scan to a file?

### to scan to a file...

1. Place the document with the intended top edge forward in the scanner insertion slot.
2. Select the Scan tab. Here you can set various characteristics of the scan. These are described in the following steps.

Output settings such as margins, layout, and media profile can be made later when you print the file.



3. Select Color or B&W scanning.
4. Select the type of original template that best describes your original. See also [how do I make original template settings](#) for details on making additional special settings.
5. Set **Scan Resolution**. This is where you determine image quality. You can set a custom dpi value, auto (program determined based on the type of original), descreen (scanner's optical resolution) or turbo mode. .
6. Use the **Size and Resize** options to determine the dimensions of your scanned image. You can use Size: "Auto" and Resize: None to keep the original's size. [See ...how do I set the input size](#) and [help on using the Resize option](#).
7. Set a destination folder or [Scan-to-email](#) as your File destination.
8. Set the **filename**. The filename can be composed of entered text and one or more automatic naming elements. A default filename is set by the program. To change the default name, press the File Name button and enter a new name.

**Automatic file naming elements** - To enter an element, position your screen cursor in the name field and press the element insert button. You can use the following automatic file naming elements:

**Counter** <###>- increasing number series. Press the Insert Counter button to add a counter to the file name. You can add "#" characters in the brackets. The number of "#" characters defines the **minimum** number of digits that will be used. The system will always examine the destination folder and start numbering after the latest file name to avoid overwriting any files already there. The system will add digits if necessary.  
*Example:* if you enter as a file name: *dogimage<###>* the system, for each scan, will create files *dogimage001, dogimage002... dogimage999... dogimage1000...* and so on.

You can also enter an exact counter number to begin saving files with a specific name - resuming the series from that point forward.

*Example:* if you enter as a file name: *dogimage<015>* the system, will begin to create files *dogimage015, dogimage016, dogimage017...* and so on.

**Date** <DATE>- The current date string in yyyyymmdd format. Press the Insert Date button to add the current date to the file name.

**Time** <TIME> - The current time string in hhmmss format. Press the Insert Time button to add the current time to the file name.

An example of the next expected file name will be displayed under the file name edit field so you can control your file name settings.

Automatic file naming can be used with single file scanning but is especially useful with batch scanning.

9. To modify the output file format, press **File Format**. Various options are available for each format.
10. To modify the Folder group, press the File destination button.

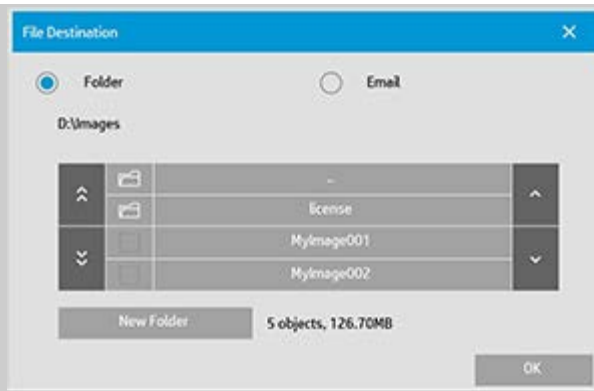

In the Change Folder dialog you can:

- use the arrows to select the folder on your disk.
- use the folder up button (marked "..") to move up a level.
- create a new folder in the current folder with the New Folder button.
- press a folder name to move your search to that folder's level.

**Network destinations:** Per default, the browse dialogs will display only local drives and folders. You can however add network locations to the system. Once added, you can use a network location and underlying folders as destinations for scan-to-file jobs. Read the help "[how do I scan to and access a network folder?](#)" for instructions.

Click OK in the Change Folder dialog when you have selected the destination folder for your file.

**Shared Files:** Files to be shared across the network should be placed in the D:\images folder. Once a file is saved in this folder it can be accessed throughout the network, from any computer running any operating system; see [how do I access shared files](#).

10. Press the Scan to file button to start the scan-to-file process and save the image.





## HP Pro Scanner

→ [how do I...?](#)

→ [the problem is...](#)

→ [alphabetical index](#)

## how do I print from files?

Printing your files is set up and controlled through a convenient Print List.

### to print from files

1. Press the Print tab.

The Print list displays the files currently selected for printing. If the list is empty or it needs changing, then you will have to select files and build your list. See:

...[how do I set up a print list?](#)



2. Press  to make quality settings (print from file). [See how do I set output quality.](#)
3. Check or change your current Setup tab settings. The current Setup tab settings such as Margins, Layout, Printer and Media Profile will apply to the whole print job.
4. Press the Print button to send the listed files to the printer.



*The scanner software's Print from File functionality is designed specifically for printing files created with the scanner software's Scan tab and is not recommended for outputting files from other sources.*





## HP Pro Scanner

→ [how do I...?](#)

→ [the problem is...](#)

→ [alphabetical index](#)

## how do I set up a print list?

File Printing is set up and controlled through a Print List that is accessible through the Print tab. This help section presents instructions for setting up your list and deleting files from your disk. See also:

...[to maintain the print list...](#) for instructions on applying settings to individual files on the list.

## setting up the print list

1. Press the Print tab.
2. You can use the Clear List button to start afresh with an empty list.
3. Press the Add to List button to reach the system File Management dialog shown below:



Only a folder's image files will be shown.

4. You select files for addition to the print list by checking the box to the left of the file name.  
**NOTE:** Only printable file formats can be accessed through "Add to List" (no DWF or external PDF).
5. Use "Select All" and "Unselect All" for multiple selections of files in the current folder.
6. See the help under [to browse, preview and select files in the file management dialog](#) for more instructions on selecting files.

7. You can also move, copy rename or delete files while you are creating your list. See the help under [how do I manage image files on my system](#) for more instructions
8. **NOTE:** If an inactivity timeout is applied to a network connection then additional logon information could be required.  
See more in: [How does the Inactivity timeout for a network connection work?](#)
9. Click the OK button to add the checked files to the print list and return to the Print tab. In the Print tab you can see the print list with the files inserted.

You can always go back and add more files from other folders with the Add to List button.





## HP Pro Scanner

→ [how do I...?](#)

→ [the problem is...](#)

→ [alphabetical index](#)

## how do I maintain the print list?

### to maintain the print list...

In the Print tab dialog, you can make settings that apply to the files in your list and the whole print job before committing the job to printing.

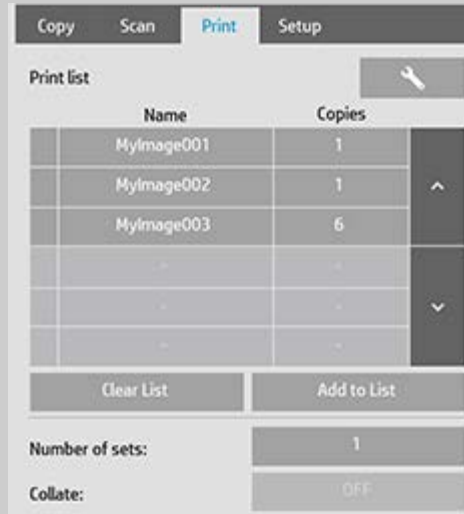

1. Set the number of copies for an individual file by pressing the Copies button to the right of the file name.
2. Set the number of times you want your whole list printed with the Number of sets button.
3. Set Collate ON if you have several number of sets to be printed as collated sets.
4. Select (press) a file name in the list to change the file's settings. The following context menu appears.



- Remove: removes the selected file from the list (not from your disk).
- Output Size: selecting this option takes you to a dialog similar to the Input Size, Output Size and Scale button group found on the Copy Tab. The file's Input size is retrieved from information in your file and you have the option to rescale the original size in the output copy. Use Output size or Scale to resize the copy.



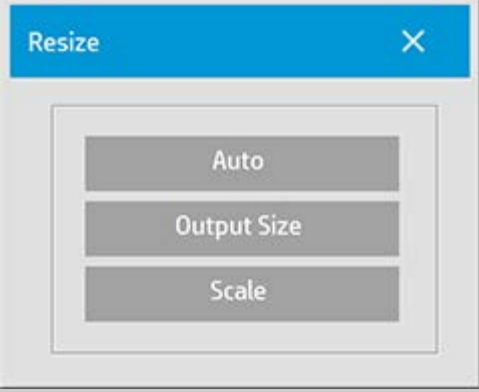

The image shows a 'Resize' dialog box with a blue header and a close button. Inside the dialog, there are three buttons: 'Auto', 'Output Size', and 'Scale'.

- Properties: displays the file's properties —full path with name, size, type and creation date. You can change the order of the file in the print list by pressing the dialog's Move up and Move down buttons. Check the Delete after print option if you want the scanner software to delete the file from your disk automatically.
- View: sends a preview of the file to the preview window. Previewing can be canceled midway by pressing the Stop button.

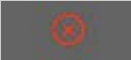



## HP Pro Scanner

→ [how do I...?](#)

→ [the problem is...](#)

→ [alphabetical index](#)

## how do I create/delete/disable an account?

The Accounting feature helps keep track of your Copy activities. Only one account (besides the Total account) can be active at a time. You can view the scanning activity information for your account in the account dialog. The account name will follow a copy job to the printer and you can then reference the account's name to view the account-print-information on the printer or network print server (if supported on printer model – see the printer's documentation).

**NOTE:** If the Administrator password has been setup and activated, you will be prompted to enter it before being able to rename, reset, create and delete accounts.

Select a topic...

...[to create a new account...](#)

...[to delete an account...](#)

...[to reset an account...](#)

### to create a new account...

1. Press the Setup tab.
2. Press the Account button. Press the Tool button .
3. In the Accounting dialog, press the New button. Enter the administrator password if prompted.

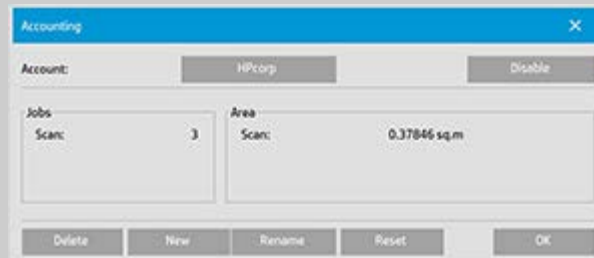

4. Enter and accept a name for your new account.

The new account will automatically become the currently active account. Every time you press the Copy button, or the Scan to file button the Account dialog list opens for you to select an account.

## to delete an account...

1. Press the Setup tab.
2. Press the Account button. Press the Tool button.



3. In the Accounting dialog, press the Delete button. Enter the administrator password if prompted.

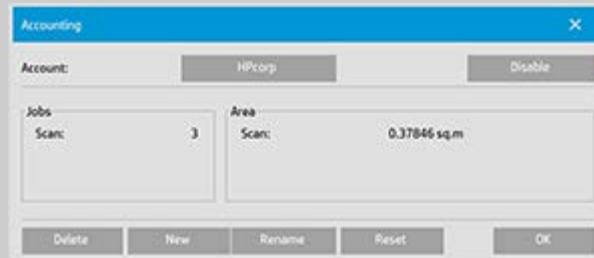

4. Confirm deletion by pressing OK.

## to reset an account...

1. Press the Setup tab.
2. Press the Account button. Press the Tool button.



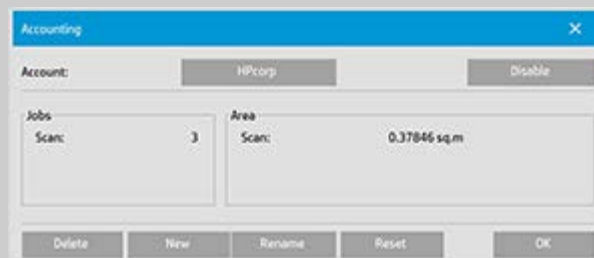

3. Select the account name you want to reset.



4. Select the Reset button. Enter the administrator password if prompted.

## to rename an account...

1. Press the Setup tab.
2. Press the Account button. If Setup tab >  > General > Use quick select lists is selected, then press the Tool button. 
3. In the Accounting dialog, press the Rename button. Enter the administrator password if prompted.

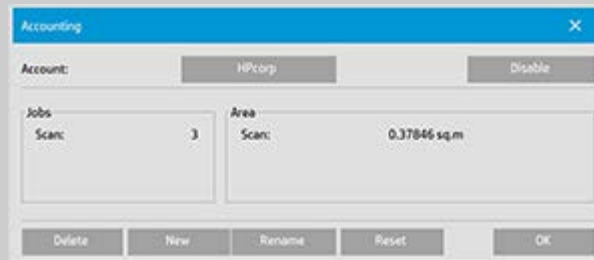

4. Enter the new name for the account and press OK.





## HP Pro Scanner

→ [how do I...?](#)

→ [the problem is...](#)

→ [alphabetical index](#)

## how do I select/activate an existing account?

Only one account (besides the Total account) can be active at a time.

### to activate/select an existing account...

1. Press the Setup tab.
2. Press the Account button.

A list of existing accounts appears.

- Use the arrows to scroll through the list and press on an account name to select it.



Every time you press the Copy button or the Scan to file button - the Account dialog list opens for you to select an account.



→ [printing instructions](#)

→ [legal information](#)

© Copyright 2012, 2015 HP Development Company, L.P



## HP Pro Scanner

→ [how do I...?](#)

→ [the problem is...](#)

→ [alphabetical index](#)

## how do I use nesting?

With Nesting you can fit multiple copies side by side using the roll/sheet width optimally and economically. Nesting is perfect for printing multiple copies, collated copies and file print lists when at least some of the copies can be fitted side by side in the output. Nesting is also useful for creating large-thumbnail collages for presenting overviews of whole sets of images.

### to use nesting...

1. Select the Setup tab.
2. Select the Layout button.

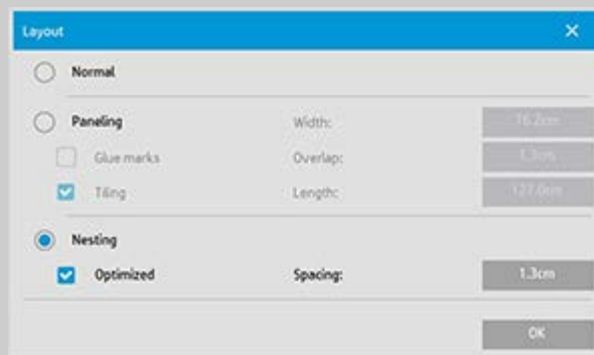

3. Select the Nesting option.
4. Make your nesting settings.

*Optimized:* your scanner software will find the best solution for Nesting with the least paper waste.

Without *Optimized* the copies are placed side by side in the order of input. Omitting *Optimized* can sometimes give a result that is easier to cut because the copies are simply lined up one after the other. The price is wasted paper. Selecting *Optimized* will always give a more economical result.

*Spacing:* determines the minimum of empty space between each nested image.

5. Make your Copy tab and Setup tab settings (such as Type of original, Margins, Media profile) as with normal copies, or else select the files for copying from your print list.

For nesting to have a purpose, you will have chosen one of the multiple copy output functions:

- Copy tab: copies set to more than 1 copy.
  - Printing multiple files/sets from the Print tab.
6. Press the Copy button (Print button when printing from file) to output your Nested copies.

*When printing multiple sets, nesting is performed within each set but not between the sets. Each new set will be started on a new strip and thereafter nested individually.*





## HP Pro Scanner

→ [how do I...?](#)

→ [the problem is...](#)

→ [alphabetical index](#)

## how do I use paneling?

### to use paneling..

1. Select the Setup tab.
2. Select the Layout button to reach the Layout dialog.



3. Select the Paneling option.
4. Make your paneling settings. Select the tiling option when you want to determine the length of each section and assemble multiple short sections vertically instead of connecting long whole image length sections. See [tell me about paneling options](#) for instructions on all the settings.
5. Set your large Output size in the Copy tab. Your Output size value is set to the size you want for the end result: that is, the size of the total image after the panels are assembled.
6. Make your Copy tab and Setup tab settings (such as Type of original, Input/Output Size, Margins, Number of copies, Media profile) as with normal copies.
7. Press the Copy button (Print button when printing from file) to output your panels.

*NOTE: Your Margins setting in the Setup tab will apply for the whole image after you connect the panels and not for each individual panel. Paneling can be used with both Scan-to-print copying and with Print-from-file copying through the Print tab.*







## HP Pro Scanner

→ [how do I...?](#)

→ [the problem is...](#)

→ [alphabetical index](#)

## how do I select a media profile?

### to select a media profile...

1. Select the Copy Tab or the Setup tab.
2. Select the Paper type or Media profile button.
3. Select the media profile from the list. Profiles with a "\*" are currently loaded in the printer.



**NOTE:** For multi-roll printers, you can choose more than one profile when there are different types of media loaded in the printer. To learn more about multi-roll management, please see the User Guide for the printer.

**NOTE:** Some printers will only display media profiles for loaded or previously loaded media.

See also:

...[how do I create a new media profile?](#)



→ [printing instructions](#)

→ [legal information](#)

© Copyright 2012, 2015 HP Development Company, L.P



## HP Pro Scanner

→ [how do I...?](#)

→ [the problem is...](#)

→ [alphabetical index](#)

## how do I create a media profile?

Before starting the following procedure, make sure that you have color-calibrated the scanner, and make sure that the media profile you intend to create is not already in the media profile list.

NOTE: With some printers you can only create media profiles for media actually loaded in the printer. These standard media types will be detected by the system and their names will appear in the list of media profiles. You can then select one of these and create a media profile for it as described below. Naming and renaming of media profiles is not possible with these printers.

### to create a new media profile...

1. Press the Setup tab.
2. Press the Media Profile button and then the Tool button.



(Alternative path: Printer > Tool button > Media Profile)

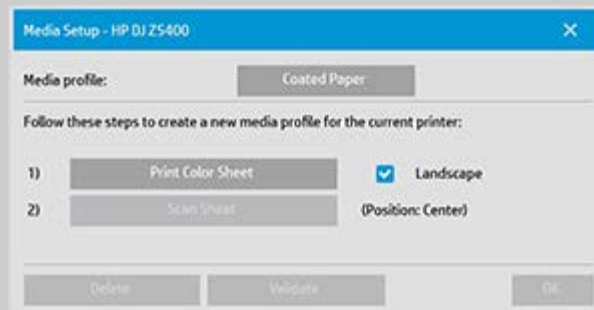

NOTE: With some printers a Calibrate RIP option will be available in the dialog as the first step. Press the button and follow the on-screen instructions to use the function.

3. Press the Print Color Sheet button to print a color patch reference sheet.  
(NOTE: Some printers will output a special test sheet just before the color sheet. You do not need to use the test sheet - only the color sheet. The color sheet looks like the image below:)

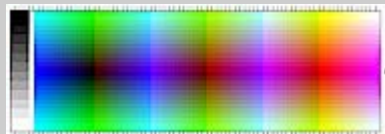

4. Load the color sheet into the scanner, aligning the sheet's

arrow with the scanner's center arrow mark.

5. Press the Name and Scan Sheet button to assign a name to your new media profile. NOTE: Some printers work with standard media profile names that comply with standard media types and you cannot select your own name - the Name and Scan Sheet button is non-existent with these printers installed.
6. Press the Enter key to accept the new name and initiate a scanning of the color sheet.

The media profile will then be active and entered in the list of available media profiles.

You can use the Delete button to delete media profiles. Only user created profiles can be deleted.

You can use the Rename button to rename media profiles if needed.

NOTE: Some printers work with standard media profile names that comply with standard media types. On these printers, the Rename button is not available in the dialog.

You can use the Validate button to check that the media profile is valid for your combination of scanner and printer.





## HP Pro Scanner

- how do I...?
- the problem is...
- alphabetical index

## solving problems

[The problem is with the scanner](#)  
(Error indicator is flashing, warning and error messages)

[The problem is a software system error](#)  
(copy software, system, online help, error codes)

[The problem is with printing and with what is printed](#)

### the problem is with the scanner

Select a topic...

[... the Error indicator light is flashing](#)

[...I get a scanner warning message](#)

### the problem is a software system error

Select a topic...

[...no scanner found](#)

[...printing error message](#)

[...system failure](#)

[...wrong interface language](#)

### the problem is with printing and with what is printed

Select a topic...

[...image is not printed - job held in queue](#)

[...image is cropped](#)

[...white space with nesting](#)



→ [printing instructions](#)

→ [legal information](#)

© Copyright 2012, 2015 HP Development Company, L.P



## the problem is the error indicator is flashing

### HP Pro Scanner

→ [how do I...?](#)

→ [the problem is...](#)

→ [alphabetical index](#)



### The scanner panel's Error Indicator will flash when the scanner detects an error

1. The actual cause of the error will often be reported through a message on your screen.
2. If not, open WIDEsystem (through the setup tab - system) and select the Status tab to view information about the error.
3. Follow the error remedy instructions provided on your screen.
4. See also error remedy instruction in this help system under [solving problems](#)

In some cases you may need technical assistance. See the documentation that came with your equipment for service information.



→ [printing instructions](#)

→ [legal information](#)

© Copyright 2012, 2015 HP Development Company, L.P.



## HP Pro Scanner

- [how do I...?](#)
- [the problem is...](#)
- [alphabetical index](#)

## the problem is no scanner was found



### if no scanner was found...

1. Check that the scanner power is ON.
2. Check that the ethernet cable between the scanner and the panel pc screen is inserted correctly.
3. In some cases, loss of communication to the scanner can be resolved by removing and reinserting the ethernet cable.
4. Press the Rescan button.





## HP Pro Scanner

- [how do I...?](#)
- [the problem is...](#)
- [alphabetical index](#)

## the problem is the image is cropped

### if your image is cropped...

If your image is cropped and no error message was displayed check one or both of the following possibilities:

Make sure that you have set the correct media width for your printer device in the copy system software. [...how do I set the printer media width?](#) and your printer's documentation for instructions.

You may have set Margins in the Setup Tab → Margins dialog. The system will crop the image with the size of the margins defined. Set these to zero if you do not want cropping and use the option "Outer Margins to add margins to the output without cropping. Note that "outer margins" will be added to the set output size and thus expand the end result. See: [...how do I set the Output margins?](#) for instructions.







## HP Pro Scanner

- [how do I...?](#)
- [the problem is...](#)
- [alphabetical index](#)

## the problem is a system failure

### if your system does not work...

When you power ON your touch screen and your scanner system does not start, you will need to recover your system using the System Recovery procedure. See: ...[how do I recover the system?](#)





## HP Pro Scanner

→ [how do I...?](#)

→ [the problem is...](#)

→ [alphabetical index](#)

## the problem is a printing error message

### if you see a printing error message...

The printer cannot be detected.

1. Select the setup tab and check that the printer is displayed next to the printer button.
2. Check that the printer is powered on.
3. Check that the printer is connected to the network or directly to the panel PC (ethernet). See ...[how do I install the printer and printer drivers](#)... for more details.
4. Check that the printer job is not held up in the queue. If so, remedy the cause. See ...[image not printed...job held in queue](#)... for more details.





## How do I make type of original templates settings?

### HP Pro Scanner

→ [how do I...?](#)

→ [the problem is...](#)

→ [alphabetical index](#)

The capture or scanning Method with relevant image enhancement settings are grouped together in a 'Type of original' template to give best results with the kind of input document to which it refers. Your selection of Color or B&W copy or scan-to-file determines which enhancement adjustments are relevant to the template.

For most assignments, the HP Scanner software contains standard Type of original templates with optimal default settings. For example, a brochure is typically a mix of photos and text while maps are line-oriented.

For a description of the templates available select...

...[templates for color copying/scanning](#)

...[templates for black and white copying/scanning](#)

To make small adjustments to a standard Type of original template or to define one of your own, see:

...[how do I define an original template?](#)

### templates for color copying/scanning

Template	Application
Photo	Photographs and posters
CAD	CAD drawings with a high level of detail
Brochure	Documents containing both photos and text
Map	Maps and graphics with a high level of detail

### templates for black and white copying/scanning

Template	Application
Photo	Photographic images that contain many shades of gray.
Map	Maps and graphics with a high level of detail
CAD Grayscale	CAD drawings with a high level of detail.
CAD B&W	CAD line drawings with a high level of detail.
Blueprint B&W	Originals with distorted foregrounds and backgrounds. The shades that create image noise are close to the shades of the image's data and are hard to differentiate.
Blueprint Grayscale	When doing blueprint original copies, if you want to get more saturated lines by printing in 100% blue instead of

	bluescale.
Sepia	Sepia originals with the same foreground/background distortions as described above for blueprint.

## About original template settings

### Method

The Method applies to the way the scanner captures and digitizes the image. The default Method settings for the built-in Type of original templates are optimal in relation to the kind of original in question and you shouldn't have to change them. Methods are only applied with BW copying.

The best method for your selected type of original is named on the Method button. You can change the method however this is not normally recommended. To change the method you press the button and the following options become available:

*Graytone:* Creates good reproductions of complicated B/W images.

*B&W Threshold:* For drawings and line art. Uses thresholds to determine whether a pixel is black or white.

*Adaptive:* For low contrast and difficult drawings. Clears up and intensifies low contrast drawings like Sepias, Blueprints, etc.

### Lightness

This same setting can also be accessed directly from the Copy tab dialog. The default Lightness value is set to zero which works well with most documents. You can change this value to make the copy lighter (positive value) or darker (negative value) and compensate for dull or faded originals.

### Saturation

Saturation indicates the intensity of a hue, or in other words the strength of a color. A high saturation makes a color's hue more intense than the same color with a low saturation value. A positive value increases saturation and a negative value decreases saturation.

### Red, green, and blue

You can adjust your copy's color balance during image capture through separate controls for each of the three color-channels Red, Green, and Blue. Adding and subtracting an amount of a color affects the whole color balance. Often it's best to keep the three channels

on the same levels. Experiment with the different effects through previewing.

Select negative values to reduce the total content of the color and select positive values to increase the total content of the color.

### **Black enhance and background clean**

The black enhance option is used to change dark graytone colors to true black.

For example, if you are copying a brochure with a mixture of text and pictures, the text will often be digitized to a color that we may see as black but really is a dark graytone. When the printer digests this graytone data, it will print the original's text with a halftone pattern, meaning scattered dots instead of solid black.

By increasing the black enhance value, you can get the text to be copied in real black and it will therefore appear clearer.

Use the black enhance option with caution, because it can change other dark colors (not only grays) into black, making small dark spots appear in the picture.

Background clean is used if you have an original with a background that is not completely white. If you want your background to appear as pure white then you can increase the background clean value. As with black enhance, background clean should be used with caution, as it can also affect some of the other light colors.

Both black enhance and background clean function as "cutoff" values in which pixels under or over a certain value are affected by the setting. You define cutting points on a scale of low to high lightness measured in values from 0 to 255. The default value of both options is zero (no effect).

Example:

You have copied an original and want to improve it by making the text blacker and the background whiter:

- Adjust the black enhance value upwards from its default of zero (to 25, for example) and thus make pixels with low lightness values go to black.
- Adjust the background clean value upwards from its default of zero (to 25, for example) and thus make the pixels at high lightness levels go to white.

You can give your copy sharper lines with the Sharpen option. The Sharpen feature identifies edges in the image and intensifies them.

### **Sharpen/Blur**

The Blur feature blends colors and thus removes unwanted "noise" during image capture. Many images are created with dithering, which is used for representing different colors in the original, and this dithering often creates unnecessary "noise" in the image. Blurring smoothes out unwanted transitions between colors. With Black and

White copying the Blur feature smoothes out gray dither by removing unwanted sharp transitions between excessive shades of gray.

Don't think of blurring as the opposite of sharpening. Sharpening works on the image's edges only while blurring looks at whole color or graytone areas and smoothes them out.

*TIP: Using Sharpen together with the Blur feature can often enhance image quality by first blurring away noise in the image and then sharpening the result.*

### **Enhance Gray**

Enhance Gray is available with color type of original setup. Press the More button to access the setting. Check the Enhance Gray option to reduce the saturation of colors on copies or prints made from low saturated color originals.

### **Invert**

This setting inverts the colors in an image. Use this command, for example, to make a positive black-and-white image negative.

### **Optimize for drawing**

Optimize for drawing is available with both color and B&W type of original setup. For color type of original setup - press the More button to access the setting.

Setting this option is recommended when copying text and drawings. It will tell the printer to output optimally in relation to clear and sharp edges. It is not advisable to activate this setting with pictures as visible bands can be created on the output.

### **Max detail**

Max detail is available with both color and B&W type of original setup. For color type of original setup - press the More button to access the setting.

Set Max detail for enhancing detailed graphics. Activating Max detail is recommended for originals with many small details such as maps and certain CAD drawings. It is not recommended with pictures as the setting will have a negative effect on color matching and graytone output.

### **Black Ink Only**

Black Ink Only is available with B&W type of original setup. Black ink only is used for creating true and neutral graytone output. Creating graytones with black ink only will create printouts that are less sensitive to current lighting conditions when viewing the results.

Note that setting Black ink Only can create output that is more grainy than normal graytone output where color ink is also used.

**NOTE: The availability of these options depend on the printer model.**



→ [printing instructions](#)

→ [legal information](#)

© Copyright 2012, 2015 HP Development Company, L.P



## HP Pro Scanner

→ [how do I...?](#)

→ [the problem is...](#)

→ [alphabetical index](#)

## How do I set the user interface options

### User interface options

Press Setup tab >  > General to reach the Options dialog shown below.

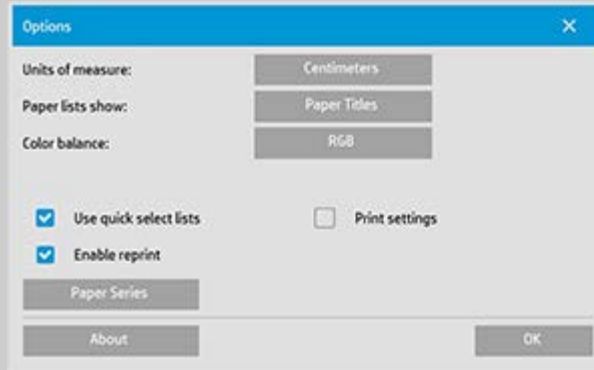

Setting ...

...[units of measure](#)

...[paper lists show](#)

...[color balance](#)

...[use quick select lists](#)

...[print settings](#)

...[enable reprint](#)

...[paper series](#)

### units of measure

Setup tab >  > General > Units of measure

With this option you can select millimeters, centimeters, or inches as your units of measurement.



### color balance



Setup tab >  > General > Color balance

This option tells your scanner software whether to display color values in Cyan, Magenta, and Yellow (CMY) or Red, Green, and Blue (RGB) when setting Type of Original options.

### paper lists show

Setup tab >  > General > Paper lists show

This option tells the scanner software whether to display paper sizes (dimensions) or paper titles (such as E-0, A3) where possible.

### use quick select lists

Setup tab >  > General > Use quick select lists

This option determines the behavior of your interface in relation to making settings for Type of original, Input size, Output size, Scale, Printer, Accounting, and Scanner. This option is set by default. The default dialog order is that you first access an east-to-use list dialog and from there you can choose a specific Setup dialog by pressing the tool button 

With Quick select lists un-selected, you reverse the above order: your interface first presents the specific Setup dialog and you must from there choose to view the List dialog with current predefined and standard values for the options.

Leave this option selected if you primarily use the scanner software with standard and customized pre defined option values. Make the option empty if you primarily need to make specific adjustments and settings for your different copy jobs and usually bypass the lists with predefined values.

You can see below the Input size button behavior with and without the Quick select lists option selected: Quick select lists ON (first) and OFF (second). The Tool button on the Input Size dialog will activate the Input Size Setup dialog, and the Input size button in the Input Size Setup dialog will activate the Input Size dialog.

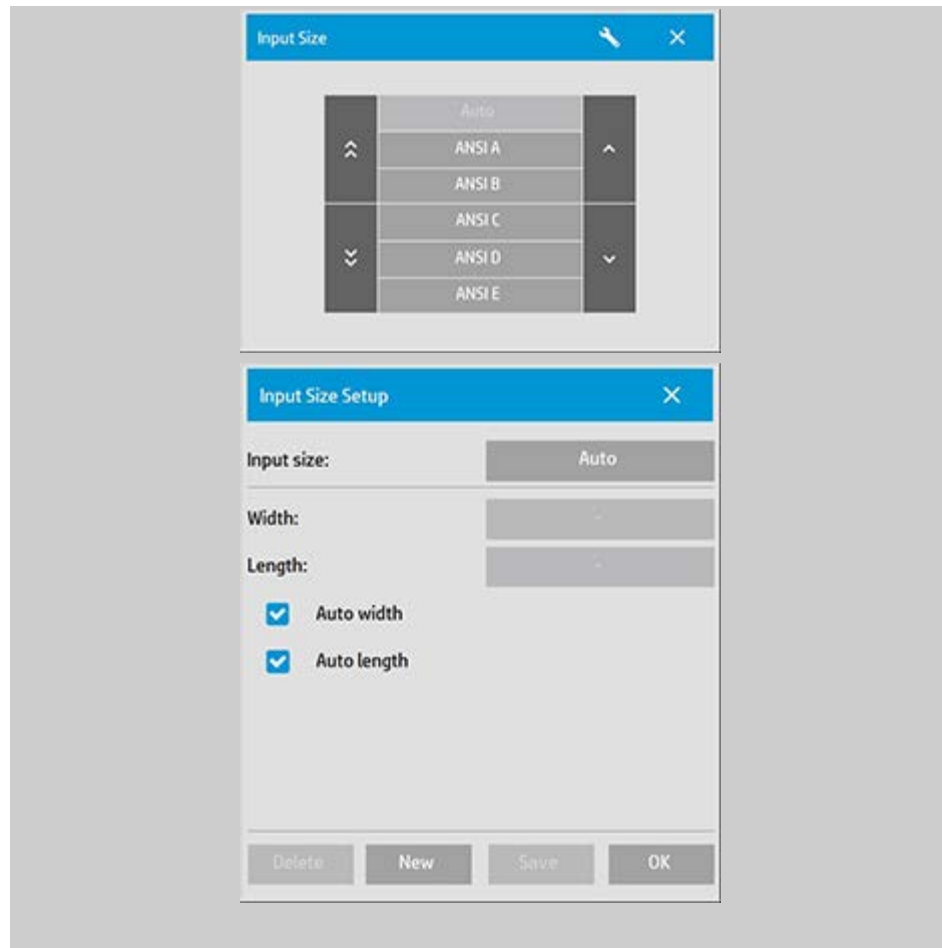

## print settings

Setup tab >  > General > Print settings

Checking this option tells the scanner software to print out an overview of all your settings together with the copy.

## enable reprint

Setup tab >  > General > Enable reprint

In the Copy Settings dialog box is a Reprint button, which can be enabled or disabled here. If the Enable reprint option is selected, the Copy tab >  > Reprint option button will reprint the last image printed. This is useful if you suddenly realize that you need more copies than you initially requested.

## paper series

Setup tab >  > General > Paper series

You can determine which types of size presets you want to appear in the size presets list (size option dialogs) when you set the Input Size or Output Size. Pressing the Paper series option displays a list of paper series' (ANSI, ARCH.....) and you select (mark) all the paper series' you want included in your size option dialogs. Be sure to select the "Custom" series if you want to have your own [custom made size presets](#) displayed in the size dialogs along with the standard sizes.



→ [printing instructions](#)

→ [legal information](#)

© Copyright 2012, 2015 HP Development Company, L.P



## HP Pro Scanner

→ [how do I...?](#)

→ [the problem is...](#)

→ [alphabetical index](#)

## Use the "Clip contents by printer's margins" option

The Margins we set in the Setup tab dialog are the copy's "output margins". But the printer itself also creates margins. The size of your printer's margins depends on the printer model and cannot be changed. You should consider the printer's margins as your minimum margins, an unprintable area, and they will be in your output whether you want them to or not.

Setup > Margins dialog:



The "Clip contents by printer's margins" option (Setup tab > Margins) lets you compensate for these uncontrollable margins. Selecting the option lets you economize paper usage by keeping unneeded margin space down to a minimum.

Selecting the option will tell the application to deduct the printer's enforced margins from your output Margins so the total margins are as you specified for the copy.

For duplicating originals without margins, you would not want output Margins either and thus the option should be deselected.

### To use the option:

Enter your printer's margin values as specified in your printer documentation through the Setup tab > Printer > Tool button > Advanced button (dialog shown below).

On some printers: You can use the Auto Detect button to prevent manual setting of printer margins and the values are set from the printer device.



### **Guidelines on using the "Clip contents by printer's margins" option:**

If you select "Clip contents by printer's margins":

1. You will also have selected a minimum output Margin at least equal to the printer's margins. The program will automatically update the values in the Setup tab's Margin values to reflect this. If you set output margins to zero or lower than the printer's, then the printer's margins are used and updated as the output Margins.
2. If the output Margins you set are higher than the printer's, then the printer's margins are deducted from the output margins meaning the scanner software only adds on the margins that the printer is missing. This means that your total margin, measured from the paper's physical edges, will be as you specified in the Setup tab - Margins option.
3. The cropping effect on the original is always determined by the value displayed on the Setup tab's Margin button whether it was automatically calculated or not. The actual cropping effect will be as displayed in your WYSIWYG preview.

If you do not select "Clip contents by printer's margins":

1. The output margins you set will be added to the printer's and applied as if measuring inwards from the paper's physical edges.
2. Only the specified Output margins will crop the copy as displayed in your preview.

You would typically want to use precise margins when copying on standard format sized sheets manually fed into the printer. When you print on paper rolls, you will often have to cut out the copy anyway.

#### **Some examples:**

If you are copying an original photo without margins then set your output margins to zero and uncheck the "Clip contents by printer's margins" option. Print the copy on a roll or a sheet larger than the specified output size to get the whole image because the printer's enforced margins will offset your copy.

Let's say you are printing a D-size poster, you want a margin of 1.5" on the copy and your printer margins are 0.5". You are duplicating the poster on a D-size sheet. Here you could select the Clip contents by printer's margins option. You can then set your output Margins to 1.5" and you will also get only a 1.5" margin from the paper's physical edges. Using the Clip contents by printer's margins option saves paper for jobs when margins and slight cropping are acceptable.



[→ printing instructions](#)

[→ legal information](#)

© Copyright 2012, 2015 HP Development Company, L.P



## HP Pro Scanner

→ [how do I...?](#)

→ [the problem is...](#)

→ [alphabetical index](#)

## how do I set paneling and tiling options and assemble panels

Paneling enables you to create huge enlargements. With Paneling you print wide format sections of your image as "panels" and then glue the panels together to reconstruct the image. In effect, the Paneling option creates a virtual printer with unlimited width capabilities. The HP Scanner software makes Paneling easy by supplying precisely placed cutting lines and guiding glue marks on the panel edges, so you can connect your panels with near-invisible seams.

Tiling is also paneling — but gives you the option to make your panel sections by dividing the image both horizontally and vertically.

See:

...[options](#)

...[assembling the panels](#)

### options

1. Width: for setting the width of the panels.

The width includes the Overlap area. The panel width can at most be as wide as the printer's printable area. For maximum sized panels, set the panel width to the same value you set as the printer's Media Width (through the Setup tab > Printer > Unprintable area) minus the printer's left/right unprintable areas.

This value should correspond with the documented printable area for your printer. The scanner software will calculate the size of the last panel. When calculating special panel widths, for example for dividing the image into equally wide panels, you must remember to add extra space for panel overlap (see the example below).

2. Overlap: determines the width of the overlap areas — that is, the edges that contain equal image data on two adjacent panels.

Large, heavy panels will need wider overlap and gluing areas than smaller panels.

3. Glue Marks: small gray arrows are printed on the panel's edges to help guide you when you connect the panels.

The glue marks will hardly be distinguishable in your large copy. The arrows vary in size: the larger the Overlap width, the larger the arrows printed. Maximum arrow size is 1" high.

4. Tiling: allows you to determine the length of your panels. Select the Tiling option when you want to determine the length of each section and assemble multiple short sections vertically

instead of connecting long whole image length sections.

Your sections will be connected both horizontally and vertically. Tiling is useful for single sheet printing but can also be used if you want to make small sections on rolls. With tiling turned off, the panel is output continuously on the printer from the image's top to its bottom. Each panel becomes as long as the image itself and the panels only have to be connected at the sides.

5. Length: set the length of your tiles if tiling is used.

### **assembling the panels**

The strips or tiles representing sections of a whole image need to be connected. Unless you have a huge table, it would be best to arrange your sections on the floor in their correct order.

If you selected the Glue Marks option, the scanner software will have made your job easier by printing the following guide-markings on the panels:

1. The Cut line: a line will be printed on the left side of panels that are to be joined with their left neighbor — that is, every panel but the first (leftmost) panel in a row.

Use a sharp knife, scissors or other cutting device to cut on the right edge of the line (to remove the line itself). The cutting line will be placed in the middle of the overlap area so slight irregular cuts can be tolerated since cutout image data will be picked up in the overlap area of the neighboring panel.

2. Glue mark arrows: after cutting the edges at the cut line, bring your panels together by overlapping with rightmost panel on top of the panel on its left.

The second panel in a row overlaps the first panel, the third overlaps the second and so on. Use the glue mark arrows to fit and glue the panels together with perfect seams (see the illustration below).

You assemble the panels by bringing the arrows printed on the overlapping panel down on top of the arrows printed on the underlying panel.



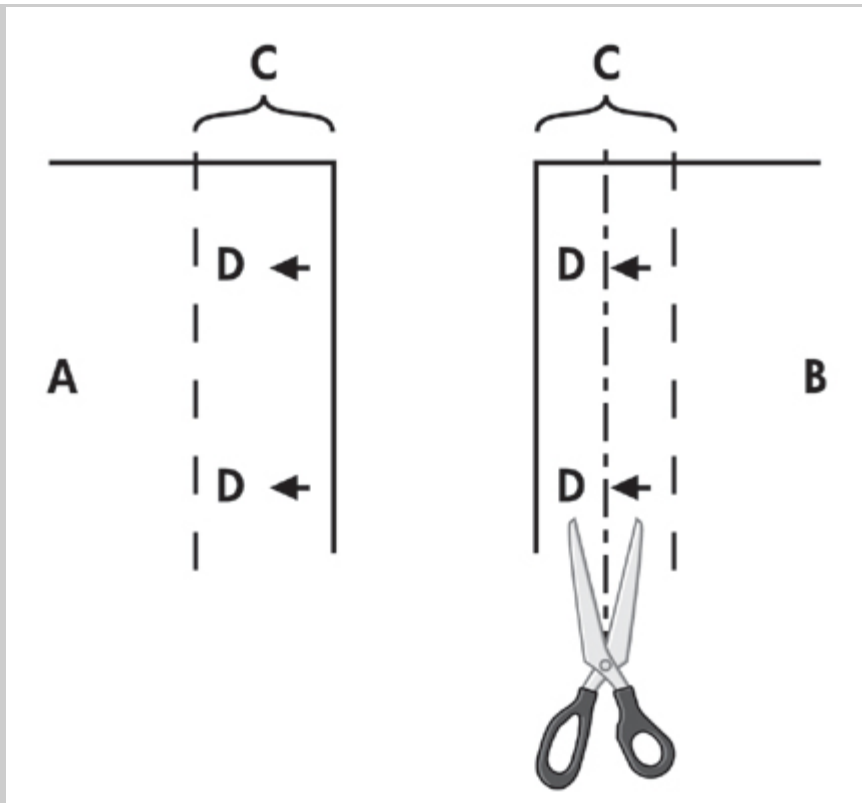

If the Tiling option is selected, cut lines and glue marks (D) will be printed, both for horizontal connection (as illustrated above) and for vertical connection.

Bring your panels together by overlapping the edges with each rightmost panel (B) on top of the panel on its left (A). The second panel in a row overlaps the first panel; the third overlaps the second and so on as illustrated below. Vertical connection (tiling only) is performed with the first row at the lowest level and then each following row overlaps the bottom edges of the tiles in the row before it.

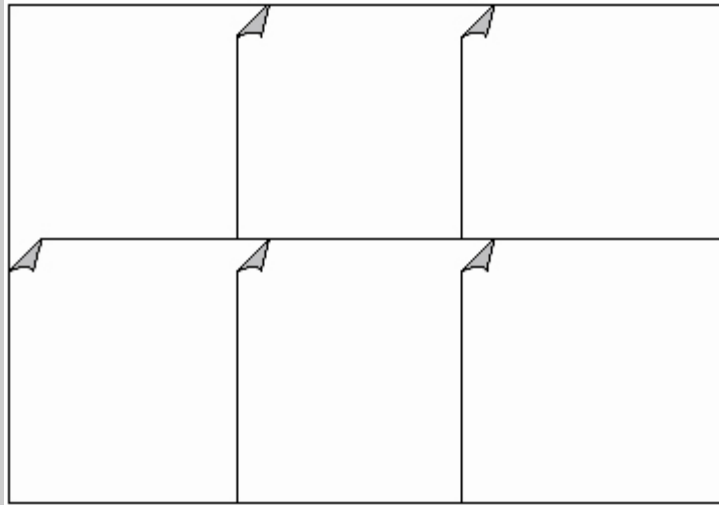



## HP Pro Scanner

→ [how do I...?](#)

→ [the problem is...](#)

→ [alphabetical index](#)

## How do I use accounting?

The Accounting feature helps keep track of your copy activities. It can be used to record your copy expenses and for billing your customers. Accounting records information on your systems scans, prints, copies and paper usage. Accounting information is stored in a simple format so it can be loaded into spreadsheets and databases.

Read information about:



...[active account](#)

...[total account](#)

...[accounting criteria](#)

...[accounting log files](#)

### active account

The active account name is displayed on the Account button in the Setup tab. If a new Account has been created, every time you press the Copy button  or the Scan to file button  the

Account dialog list opens for you to select an account. Only one account (besides the Total account) can be active at a time. See: ...[how do I create/delete/disable an account?](#)

### total account

The built-in Total account runs constantly in the background. Its purpose is to record all your system's activities. Activities registered on a current active account will automatically be recorded in the Total account as well. The Total account cannot be deleted, reset or disabled.

### accounting criteria

The activities that update an account are: Copy, Collate Copy, Scan to File, Print from File. The accounting system records the number of times the system scans, prints and copies (straight-through scan and print). Scan to File updates only the scan fields, Print from File only the print fields, while Copy and Collate Copy update both. The number of square feet or square meters for scanning and printing activities are calculated from the Input size and Output size settings. The calculations for paper usage in square feet incorporate the full

printer Media Width as set in the Setup tab > Printer Tool button > Printer Margins dialog.

The following table shows how your scanner software actions update the Accounting fields:

Action	Account Fields					
	Jobs			Area		
	Scan	Print	Copy	Scan	Print	Paper
Copy	No	No	Yes	Yes	Yes	Yes
Collate Copy	Yes	Yes	No	Yes	Yes	Yes
Scan to File	Yes	No	No	Yes	No	No
Print from File	No	Yes	No	No	Yes	Yes

### accounting log files

Your scanner software creates special log files for direct integration into your invoicing and bookkeeping systems. Accounting data is organized in files for easy loading into spreadsheets and/or databases.

Accounting data files are stored in the scanner software Accounting file folder. There is one file for each account you create. The files are named: <account name>.csv. These (.csv) files can be viewed raw with standard text editors like MS Notepad and they can be loaded into popular spreadsheet and database applications.

The files contain lines of comma-separated fields. Each line represents a single action and a line's fields contain values recorded during the action. The actions that trigger the creation of a new line are: Copy, Collate Copy, Scan to File, Print from File.





## HP Pro Scanner

- [how do I...?](#)
- [the problem is...](#)
- [alphabetical index](#)

## the problem is white space with nesting

### if there is too much white space with nesting...

If there is space for another image on your media when using nesting, then make sure you have set the printer media width in your copy system software. See:

...[how do I set the printer media width?](#)



→ [printing instructions](#)

→ [legal information](#)

© Copyright 2012, 2015 HP Development Company, L.P



## alphabetical index

### HP Pro Scanner

→ [how do I...?](#)

→ [the problem is...](#)

→ [alphabetical index](#)

[A](#) - [B](#) - [C](#) - [D](#) - [E](#) - [F](#) - [G](#) - [H](#) - [I](#) - [J](#) - [K](#) - [L](#) - [M](#) - [N](#) - [O](#) - [P](#) - [Q](#) - [R](#) - [S](#) - [T](#) - [U](#) - [V](#) - [W](#) - [X](#) - [Y](#) - [Z](#)

### A

[accessing shared files](#)

[accounting](#)

[about - using](#)

[creating new](#)

[deleting](#)

[log files](#)

[select/activate](#)

[total and active account, about](#)

[adaptive - method](#)

[Administrator password - enable/disable](#)

[auto-alignment - copy and scan-to-file](#)

[auto-detect scan length- limit](#)

[auto input size](#)

[auto landscape - input portrait and output landscape](#)

[auto output size](#)

[auto preview - scanner options](#)

[automatic file naming](#)

### B

[B/W templates](#)

[background clean - type of original option](#)

[back-ups during scanning - scan speed](#)

[Batch copy and batch scan-to-file](#)

[black ink only - print from file settings](#)

[black ink only - type of original - copy and scan to file](#)

[black and white Threshold - method](#)

[blur - type of original option](#)

### C

[calibrate rip option](#)

[calibration - scanner](#)

[Clip contents by printer's margins](#)

[CMY color balance](#)

[collate - copy sets](#)

[color accuracy - optimize](#)  
[connect to a network](#)  
[copies - making](#)  
[copies - set how many](#)  
[copies - sets \(collate\)](#)  
[copy - thick media](#)  
[copy quality](#)  
[cropped image - problem](#)

## D

[Debugging files - Troubleshooting](#)  
[Default settings](#)  
    [Save current settings](#)  
    [Restore factory defaults](#)  
[delete files - from system](#)  
[descreen](#)  
[Destination - scan to file](#)  
[duplicate copy \(in a file\)](#)

## E

[eject paper - scanner options](#)  
[Email - scan to](#)  
[enable reprint](#)  
[enhance gray - type of original option](#)  
[exit button](#)  
[Extended thickness - stitching offsets](#)

## F

[File duplicate option](#)  
[File Management](#)  
files - scan to file ...  
    [how to scan to file...](#)  
    [batch scan-to-file](#)  
    [quality settings](#)  
    [delete files from hard disk](#)  
[files shared - access to...](#)  
[Folder button \(at bottom of screen\)](#)  
[folding options](#)  
[FTP/WebDAV](#)

## G

[getting started - setup instructions](#)  
[glass plate - replace on HP HD Pro Scanner](#)  
[glass plate - replace on HP SD Pro Scanner](#)  
[graytone - method](#)

H

I

[image cropped - problem](#)

[image overview - zoom viewing](#)

[ink printer original - copy quality](#)

[ink printer original - print](#)

[input size](#)

[install printer and printer drivers](#)

[interface language - how to change](#)

[interface options](#)

[insertion slot - raise for thick media](#)

[invert - type of original option](#)

J

K

L

[lamp unit - replace on HP HD Pro Scanner](#)

[landscape \(auto\) - input portrait and output landscape](#)

[language of interface - change](#)

length

[\\_input size](#)

[\\_output size](#)

[lightness - type of original option](#)

[limit auto detect scan length - scanner options](#)

[Link \(margins, outer margins\)](#)

lists - print

[setting up print list](#)

[to maintain the print list](#)

[delete files from the hard disk](#)

[remove files from the print list](#)

M

maintenance

[procedures](#)

[replace scanner parts HP HD Pro scanner](#)

[replace glass plate HP SD Pro Scanner](#)

margins

[Margins - setting](#)

[Outer margins](#)

[Clip contents by printer margins](#)

[max detail - type of original option](#)

[max detail - print from file settings](#)

media in printer, media profile

[media profile selection](#)

- [media profile creation](#)
- [media handling](#)
- media size
  - [paper series](#)
  - [width, printer](#)
- [media offset](#)
- [menu shortcuts - quick select lists](#)
- message - about scanner
  - [viewing](#)
  - [warning](#)
- [method - type of original option](#)
- [mirror the image - copying and scan-to-file](#)
- [move image tool](#)
- [multiple printers](#)
- [multipage scan to file](#)

## N

- [name and scan sheet button - during media profile creation](#)
- nesting
  - [how](#)
  - [white space - problem](#)
- network
  - [connecting system to a settings](#)
  - [Set up scan network destination and folder access](#)
  - [Set up FTP connections for scanning](#)
- [no scanner found message](#)
- [number of copies](#)

## O

- [one to one pixel view](#)
- [optical resolution \(descreen\)](#)
- [optimize for drawing - type of original option](#)
- [optimize for drawing - print from file settings](#)
- [optimize - color accuracy](#)
- original - type of ... template
  - [settings](#)
  - [defining](#)
  - [selecting](#)
  - [templates color](#)
  - [templates B&W](#)
- [output destination](#)
- [output margins - setting](#)
- [outer margins - setting](#)
- [output quality](#)
- output size
  - [setting](#)



[printer media width](#)

P

[page order](#)

paneling

[setting options and assembling  
using](#)

paper frame

[paper lists show](#)

paper loading

[how to set load preferences -media handling](#)

[paper series](#)

[paper size preset - create custom](#)

password

[administrator](#)

[network - FTP/WebDAV](#)

[position paper frame tool](#)

[power up/down timer](#)

[preferences - for scanner and user interface](#)

preview

[resolution - scan options](#)

[tools](#)

[print color sheet](#)

print from file

[how to...](#)

[lists - setting up](#)

[Print to File for debugging](#)

print list

[select all option](#)

[maintaining print lists](#)

[number of copies option- in list](#)

[setup the print list](#)

[print settings - print out an overview](#)

Printer

[driver and installation](#)

[margins](#)

[media width](#)

printer - queue

[viewing the queue](#)

[job held in queue](#)

[printing error](#)

[printing from files](#)

[printing from file - quality](#)

[Print Paper Border](#)

Q

quality settings

[copy quality](#)  
[scan to file quality](#)  
[print from file - quality](#)

queue - printer  
[viewing the queue](#)  
[job held in queue](#)  
[quick select lists](#)

## R

[recover system](#)  
[red, green, blue - type of original option](#)  
replace - scanner parts  
[glass plate - HP HD Pro Scanner](#)  
[glass plate - HP SD Pro Scanner](#)  
[white background](#)  
[lamp unit](#)  
[reprint, using and enabling](#)  
[reset button](#)  
[resize paper frame tool](#)  
[resolution - scan to file](#)  
[resolution - preview dpi](#)  
[rewind paper - scanner options](#)  
[rotate the output 90 degrees](#)

## S

[saturation - type of original option](#)  
[scale -setting](#)  
[scale - create custom](#)  
[SCANDump](#)  
scan - thick media  
[how to...](#)  
scan to file  
[how to...](#)  
[batch scan-to-file](#)  
[quality settings](#)  
[multiple pages into a single file](#)  
scanner device  
[options and preferences](#)  
scanner maintenance  
[performing](#)  
[replace scanner parts](#)  
[scanner messages](#)  
scanner parts - replacing  
[glass plate - HP HD Pro Scanner](#)  
[glass plate - HP SD Pro Scanner](#)  
[white background](#)

- [lamp unit](#)
- scanner software
  - [changing language](#)
  - [scanner speed - scanner options](#)
  - [scan tab](#)
  - setup security
    - [administrator password](#)
    - [store network connections](#)
    - [disable USB storage](#)
  - setup scanner
    - [about scanner options and preferences](#)
    - [about user interface options](#)
    - [auto preview](#)
    - [eject paper](#)
    - [height auto-detect method](#)
    - [language](#)
    - [limit auto-detect scan length](#)
    - [preview dpi](#)
    - [printer media width](#)
    - [rewind paper](#)
    - [scan speed](#)
    - [units of measurement](#)
    - [user interface options](#)
    - [sharpen - type of original option](#)
  - [shared files - access](#)
  - [shortcuts, menu](#)
  - [show paper size in lists](#)
  - [shut down system](#)
  - size
    - [output size - set](#)
    - [input size - set](#)
    - [paper size preset - create custom](#)
    - [solving problems](#)
  - [stop button](#)
  - [system recovery](#)
  - [synchronous printing \(multiple printers\)](#)

T

- [templates color](#)
- [templates B&W](#)
- thick media
  - [copying and scanning thick media](#)
  - [insertion slot height](#)
  - [extended thickness setting](#)
- [tiling](#)
- [time zone - setting](#)
- [timer - power up and power down](#)
- [Troubleshooting](#)

[turbo resolution - scan, copy quality](#)

type of original templates

[setting options](#)

[definition and creation of...](#)

[selection of...](#)

[templates color](#)

[templates B&W](#)

U

[units of measure](#)

[Update software](#)

[use quick select lists](#)

V

W

[warning message](#)

[welcome page - to help system](#)

[white background - replace](#)

[white space with nesting](#)

WIDEsystem

[about](#)

width

[input size](#)

[output size](#)

[printer media](#)

X

Y

Z

[zoom all tool](#)

[zoom in tool](#)

[zoom out tool](#)





## HP Pro Scanner

→ [how do I...?](#)

→ [the problem is...](#)

→ [alphabetical index](#)

## how do I set the scanner system power up/down timer?

**NOTE:** The availability of the power timer feature depends on your scanner model.

Automatic power up/down saves energy and will lengthen the life span for your scanner lamp. Typically, you would set the scanner to power down sometime after work hours and power up at least an hour before you arrive in the morning so your system is warmed up and ready for use.

Note that The following applies when the power up/down timer is set:

If a scan is being done when power off time is reached, automatic power off is delayed by 15 minutes.

If the scanner is manually started, 3 hours will have to pass before it goes into standby.

## to set the scanner system power up/down timer...

1. Press the Setup tab
2. Press  > System > Advanced
3. Press the *Sleep Timers* button

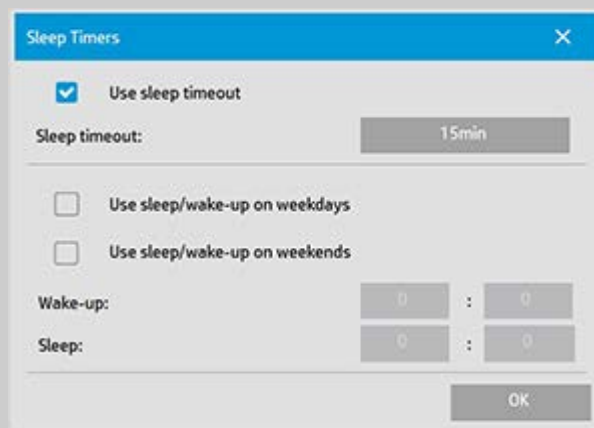

4. *Use sleep time out* - select this option if you wish the scanner to go into sleep mode after an idle time interval that you determine through the *Sleep timeout* button.
5. The 2 options: *Use Sleep/wakup on weekdays* and *Use Sleep/wakup on weekends* allow you to define the days you wish the scanner to go into sleep or wake modes. For example, you may only want to have the scanner power up and off during work days i.e., week days.

6. Set the optimal wakeup/sleep times according to your needs.  
Times are set as hours : minutes (24 hour clock)
7. Press the OK button to confirm your settings.



→ [printing instructions](#)

→ [legal information](#)

© Copyright 2012, 2015 HP Development Company, L.P



## how do I update the software or recover the system ?

### HP Pro Scanner

- [how do I...?](#)
- [the problem is...](#)
- [alphabetical index](#)

### to update the software or recover your system...

1. Press the Setup tab
2. Press  > System > Advanced
3. Press the *Update Software* button
4. Confirm that you wish to enter the Software Update and Recovery mode to proceed.
5. The system will shut down and restart automatically in recovery mode - and present your options.
5. Follow the instructions on your screen.
6. After updating the software/ system recovery you must run Calibration. See:

...[how do I... maintenance procedures](#)





## HP Pro Scanner

→ [how do I...?](#)

→ [the problem is...](#)

→ [alphabetical index](#)

## how do I set the printer media width?

Your work may involve printing on different media widths. For example, with some jobs you will print on 36" wide media roll and for other jobs, you will change to a 24" media roll.

Whatever the case, **the program needs to know the width of the media currently loaded on the printer.**

The steps involved for setting the media width in the program depend on your printer model. Newer printer models will support automatic detection of the media width while older models may require manual setting. See your printer's documentation for determining its automatic media width detection capabilities.

Regardless of your printer model, it is recommended to view and control your printer media width settings before committing a large and costly printing job. The printer media width setting can be viewed in the *Setup tab > Printer > Tool button > Advanced* dialog. From here you can also change the Media width setting when you change the printer media roll to one of a different width.

The instructions in this topic describe:

1. [Viewing and accessing the printer media width settings](#)
2. [Setting the printer media width on printers WITH support for automatic media width detection - at startup and after changing the paper roll.](#)
3. [Setting the printer media width on printers WITHOUT support for automatic media width detection, at start up and manually after changing the paper roll.](#)

## to view/access the printer media width settings ...

1. Select the setup tab.
2. Select the Printer button and then the Tool button







3. Select the Advanced button. The current Media width setting (value) is displayed on the Media width button.



### Setting the paper media width on printers WITH support for automatic media width detection...

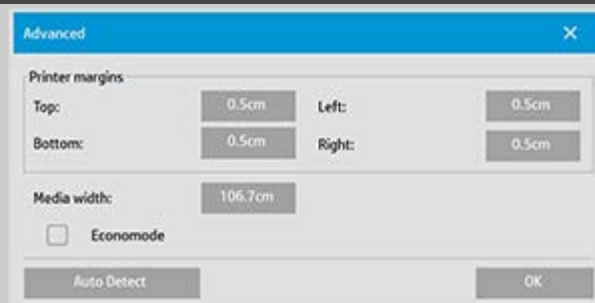

1. *At start up* - The program will automatically detect the width of the roll currently loaded on the printer. The value will be displayed in the Media width button in the Setup tab>Printer>Tool button>Advanced dialog.
2. *If you change the paper roll to one of another width* - After changing the roll, access the Setup tab>Printer>Tool button>Advanced dialog. Press the Auto detect button to retrieve the new media width value from the printer. The new value will be displayed in the Media width button.
3. Select OK to finish.

## Setting the paper media width on printers WITHOUT support for automatic media width detection...



1. *At start up* - The program will set the media width value stored with the printer driver. This is normally the maximum output width of the printer. If you are using a roll smaller than the maximum width of the printer, you will need to change the width manually. Access the Setup tab>Printer>Tool button>Advanced dialog. Press the Media width button to enter a new value with the on-screen keyboard and press the keyboard's Enter key to confirm. The media width value will be displayed in the Media width button.
2. *If you change the paper roll to one of another width* - You need to change the width value manually. Access the Setup tab>Printer>Tool button>Advanced dialog. Press the Media width button to enter a new value with the on-screen keyboard and press the keyboard's Enter key to confirm. The media width value will be displayed in the Media width button.
3. Select OK to finish.





## HP Pro Scanner

→ [how do I...?](#)

→ [the problem is...](#)

→ [alphabetical index](#)

## how do I change the interface language?

### to change the interface language...

If the Administrator password has been setup and activated, you will be prompted to enter it before being able to change the system interface language.

1. Press Setup Tab > 
2. Select System
3. Press the Advanced button.
4. Enter the Administrator password if prompted by the system.
5. Press the Change Language button.
6. Select the language from those available.
7. The system will reboot to apply the new language.



→ [printing instructions](#)

→ [legal information](#)

© Copyright 2012, 2015 HP Development Company, L.P



## HP Pro Scanner

- [how do I...?](#)
- [the problem is...](#)
- [alphabetical index](#)

## legal notices

[Notice](#)

[Trademarks](#)

### notice

The information contained in this document is subject to change without notice.

HP makes no warranty of any kind with regard to this material, including, but not limited to, the implied warranties of merchantability and fitness for a particular purpose.

HP shall not be liable for errors contained herein or for incidental or consequential damages in connection with the furnishing, performance, or use of this material.

No part of this document may be photocopied, printed, or translated to another language without the prior written consent of HP.

### trademarks

HP, the HP logo, Designjet, PageWide and Jetdirect are trademarks of HP.

Any other trademarks referenced herein are the properties of their respective owners.

© Copyright 2015 HP Development Company, L.P.

Large Format Division

Camí de Can Graells 1-21 · 08174

Sant Cugat del Vallès

Barcelona · Spain





## HP Pro Scanner

- [how do I...?](#)
- [the problem is...](#)
- [alphabetical index](#)

## How do I print help pages

### to print your help pages...

The default printer on your scanner system is your large-format printer. We advise you to use the 'HP SD/HD Pro Scanner Doc' CD if you want to print any help pages. The contents are identical to your online help and will open in your browser.





## HP Pro Scanner

→ [how do I...?](#)

→ [the problem is...](#)

→ [alphabetical index](#)

## How do I view information about the scanner

### WIDEsystem

WIDEsystem is an application designed to monitor and control the functionality of your scanner and contains the drivers required by your system.

To reach WIDEsystem Setup tab >  > System > WIDEsystem

The programs main features are:

#### System Status

View the scanner system's status, called the Scanner Mode, by exiting your scanner system and on the Active Desktop, selecting the WIDEsystem scanner icon on the system tray. Status messages include remaining warm-up time, interface connection errors, and an indication that the scanner is ready for scanning.

View useful Error messages that relate to the current Scanner Mode.

View the load status of the original (media) to be scanned.

#### Scanner Information

View information on the scanner system's firmware and hardware revisions. The information helps you keep track of your upgrades and is useful for support purposes.

Initiate a scan of the connected HP Pro Scanner.





## HP Pro Scanner

- [how do I...?](#)
- [the problem is...](#)
- [alphabetical index](#)

## how do I define special scanner setup options?

Select a topic...

- ...[to access the scanner setup options...](#)
- ...[paper load](#)
- ...[media offset](#)
- ...[extended thickness settings](#)

### to access the special scanner setup options...

1. Press the Setup tab.
2. Press 
3. Press the Scanning button.

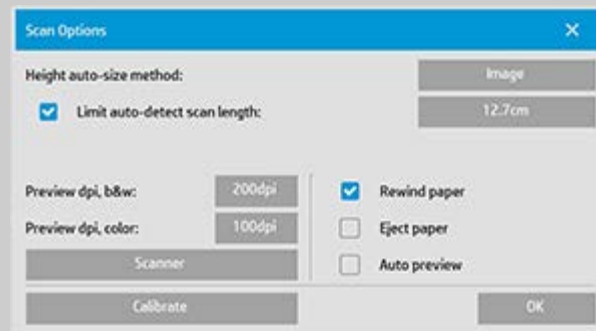

4. Press the Scanner button.

### Media Handling

Select the Media Handling button

1. Select Automatic load or leave unselected for manual loading.
2. Set the Load delay factor for automatic paper loading to give you time to position the original correctly.
3. Soft handling - set this to help correct paper jam errors while scanning. Note that scanning speed is reduced.
4. Fast Load - For extra fast feeding of originals - used for batch scanning.

## media offset

Select the Media Offsets button

1. To get very high accuracy, modify the vertical precision from zero to a value between -1% and 1%.

Positive settings mean that the distance between scan lines will be increased, and negative settings mean that the distance between scan lines will be decreased.

When you exit the Scanner Setup dialog, the modified value is stored in non-volatile memory in the scanner and can only be changed by re-doing the setup.

1. Paper offset -/ Top, Side, Bottom

The Paper Offset values determine the position of the scan area. You can use the option to adjust the capture area's position. This is done by moving the area to the right and down.

- *Top media offset*: Move the area up or down. Perhaps there are details close to the top edge that you want included or excluded in the scan.
- *Bottom media offset*: Move the scan area bottom marker up or down. Perhaps there are details close to the bottom edge that you want included or excluded in the scan or you wish to fine-adjust the scanner's calculation of size length.
- *Side media offset*: Move the area to the left to include/exclude details close to the original's left edge.

## extended thickness (stitching offsets)

Stitching is the scanner's automatic control of boundaries between the cameras and creation of correct overlap of image data. Stitching errors can happen when the original is not evenly pressed down on the scanner's glass plate. The most common case involving stitching errors is when scanning stiff thick originals with the pressure platen raised for thick-original scanning.

**NOTE:** The extended thickness settings apply only with the HP HD Pro Scanner

Normally, only stiff media will affect stitching. A flexible media will usually be stitched correctly regardless of its thickness.



This option will let you adjust the normal stitching parameters to accommodate thick media scanning if needed.

Select the Extended Thickness button

1. If the lines seem uneven, check the box labeled Enable extended thickness handling.
2. Change the value for each of the scanner's camera pairs. Normally, only positive values should be used.
3. Make test scans and readjust the values until you are satisfied that the lines are stitched correctly.
4. Click OK to accept your settings.



[→ printing instructions](#)

[→ legal information](#)

© Copyright 2012, 2015 HP Development Company, L.P



## HP Pro Scanner

- [how do I...?](#)
- [the problem is...](#)
- [alphabetical index](#)

## how do I shut down my system?

### to shut down your system...

1. Press the Exit button  .
2. Confirm that you wish to shut down the system.
3. Power OFF the scanner.





## HP Pro Scanner

- [how do I...?](#)
- [the problem is...](#)
- [alphabetical index](#)

## the problem is with the interface language

### if the user interface is not in the correct language...

When you installed your scanner system, the wrong language was installed in the final step.

You need to change the interface language. See:

...[how do I change the scanner system interface language?](#)





## HP Pro Scanner

→ [how do I...?](#)

→ [the problem is...](#)

→ [alphabetical index](#)

## how do I create a custom scale size?

You can set a custom scale size value from the copy tab and from the scan tab.

### to create a custom scale size...

1. Press the Copy tab → Output size if you are performing a Copy job

or...

Press the Scan tab → Resize if you are performing a Scan to file job.

2. Press the Scale button and then the Tool button .

3. In the Scale Setup dialog, press the New button.

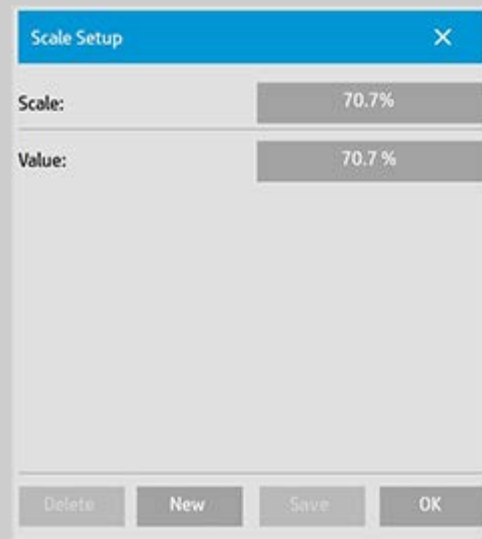

4. Enter a name for your new scale. Using the scale value itself as the name is recommended (i.e., "72%").
5. Press the Value button and set the scale value.
6. Press the Save button and then OK to confirm.

Your new scale will join the standard scales in the Scale presets list.



[→ printing instructions](#)

[→ legal information](#)

© Copyright 2012, 2015 HP Development Company, L.P



## HP Pro Scanner

→ [how do I...?](#)

→ [the problem is...](#)

→ [alphabetical index](#)

## how do I create a custom paper Size preset (Input size and Output size)?

The following instructions apply for creating either a custom Input Size - paper size preset or a custom Output Size - paper size preset.

### to create a custom input or output size...

1. Press the Copy tab or Scan Tab.

2. Press the Input Size option and then the Tool button.



3. The Output size dialog is reached through the Output size -> Output Size, if in the Copy tab, and through the Resize -> Size option, if in the Scan tab, and then the Tool button.



3. In the Size Setup dialog, press the New button.

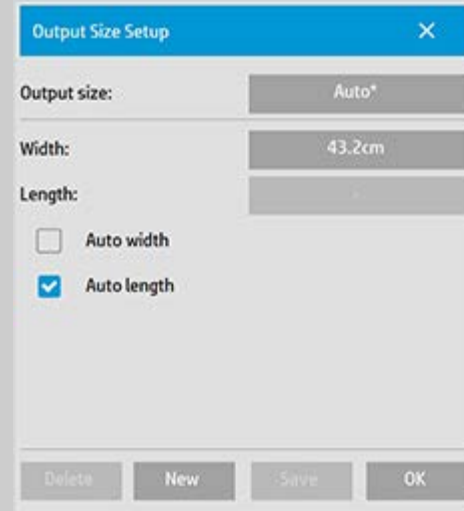

4. Enter a name for your new size. The name could describe a certain group of copies or the size itself i.e., "23x50".

5. Press the Width and length buttons and set the values. The Auto options can also be used.

6. Press the Save button and then OK to confirm.

Your new size preset will join the standard sizes in the Size presets lists.



[→ printing instructions](#)

[→ legal information](#)

© Copyright 2012, 2015 HP Development Company, L.P



## HP Pro Scanner

→ [how do I...?](#)

→ [the problem is...](#)

→ [alphabetical index](#)

## how do I set the output quality?

### Quality settings for - Copy, Print, Scan

**Copy:** Quality setting from the copy tab includes both scan and basic print quality options. Both Scan and Print Quality settings are used with the process.

**Print:** Print from file - special print quality settings can be made from the print tab.

**Scan:** scan to file - scan quality (resolution) settings can be made from the scan tab.

### Copy quality

With copying, you can set both scan (input) and print (output) quality values.

1. Press the Copy tab

2. Press







Ink Printer Original: will improve the result of your copy or print if the original to be scanned has been printed with an inkjet printer. Press OK button to apply.

3. Press the Copy tab > Quality button.

Define a new quality based on both print and scan quality as described below.

#### Scan Quality

For the scanner you set scan resolution in dpi (dots per inch).

*Descreen* tells the scanner to scan with the scanner's optical resolution and relay the data to the software without interpolation. Optimal conversion to the set dpi or quality is then performed by the software. Gives superior results with raster originals. Scanning speed is reduced.

*Turbo*: You set the Scan resolution value and then select Turbo. This will basically double the scanning speed but with a reduction on image quality. Turbo resolution processing involves speeding up the paper's movement, reduction of captured scan data in the scan direction and resampling to create the image resolution as set in Scan Resolution options. Turbo mode has no effect for resolutions below 300 dpi.

#### Print Quality

You select Fast, Normal or Best settings.

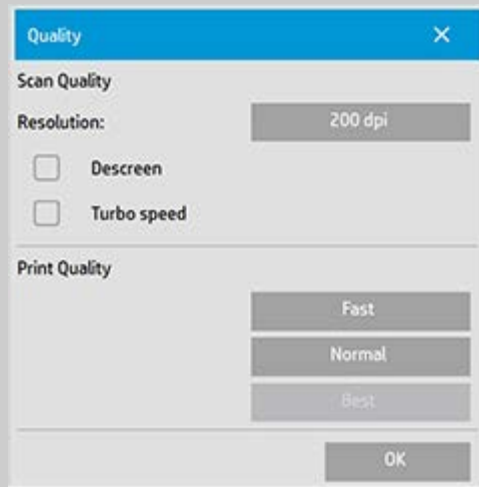

Press OK button to apply.

NOTE: For HP PageWide printers the quality settings are defined as Lines/fast, Uniform areas and High detail.

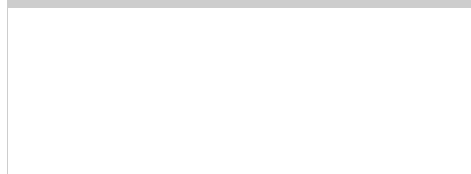

## Print quality

With printing from an existing file in the print tab, you set print (output) quality options.

1. Press the Print tab.

2. Press 

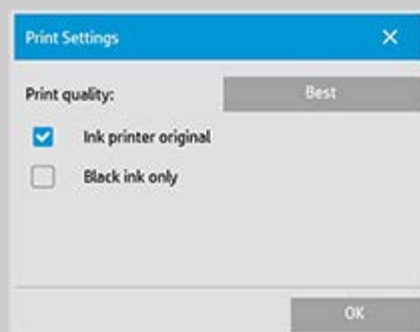

Press the *Print Quality* button to choose a fast, normal or best output quality setting.

*Ink Printer Original:* to improve the result of your copy or print if the original that was scanned to create the file had been printed with an inkjet printer.

*Black Ink Only:* This option will only affect printed output from **graytone image files**. For creating true and neutral graytone output. Creating graytones with black ink only will create printouts that are less sensitive to current lighting conditions when viewing the results. Note that setting Black ink Only can create output that is more grainy than normal graytone output where color ink is also used.

*Optimize for drawing:* Recommended with text and drawings. Tells the printer to output optimally in relation to clear and sharp edges. Not advisable to use with pictures as visible bands can be created on the output.

*Max detail:* For enhancing detailed graphics. Recommended for originals with many small details such as maps and certain CAD drawings. Not recommended with pictures as the setting will have a negative effect on color matching and graytone output.

Press OK button to apply.

NOTE: The availability of these options depend on the printer model.

NOTE: Some of these special print quality options can also be defined within a type of original template through the copy tab. See: [how do I define an original template?](#) for more information.

NOTE: For HP PageWide printers the quality settings are defined as Lines/fast, Uniform areas and High detail.

## **Scan quality**

With scan-to-file in the Scan tab, you set scan (input) quality factors.

1. Press the Scan Tab.
2. Press the Scan Resolution button.

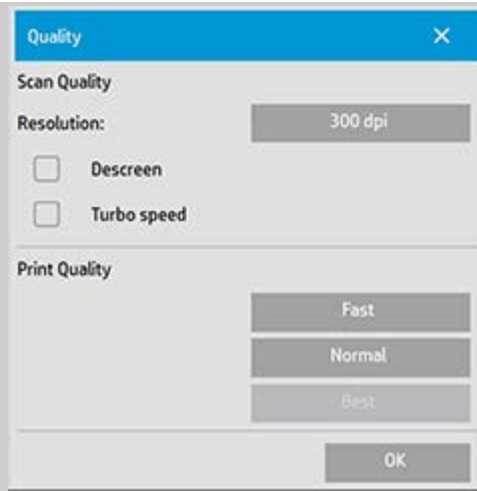

## Scan Quality

Scan Resolution - You set a scan resolution value in dpi (dots per inch).

Uncheck *Auto* to set your own dpi value.

*Descreen* tells the scanner to scan with the scanner's optical resolution and relay the data to the software without interpolation. Optimal conversion to the set dpi or quality is then performed by the software. Gives superior results with raster originals. Scanning speed is reduced.

*Turbo*: You set the Scan resolution value and then select Turbo. This will basically double the scanning speed but with a reduction on image quality. Turbo resolution processing involves speeding up the paper's movement, reduction of captured scan data in the scan direction and resampling to create the image resolution as set in Scan Resolution options. Turbo mode has no effect for resolutions below 300 dpi.

Press OK button to apply.





## HP Pro Scanner

- [how do I...?](#)
- [the problem is...](#)
- [alphabetical index](#)

## how do I install the printer and printer drivers?

### Network connection through the LAN ...

1. Make sure the printer you wish to use is configured and setup on the LAN to be recognized by other devices.
2. Connect your panel PC to the LAN.
3. Select the Setup Tab
4. Select  > System.
5. Select "Install Printer Driver". This opens the printer installer wizard. Follow the installation instructions that appear on your screen.





## HP Pro Scanner

→ [how do I...?](#)

→ [the problem is...](#)

→ [alphabetical index](#)

## how do I connect to a network?

### to connect your scanner to a network...

These actions will make your system recognizable to others on the network.

**NOTE:** If the Administrator password has been setup and activated, you will be prompted for it before being able to make the network settings.

1. Connect the RJ45 network cable to the Ethernet port at the back of your touch screen.
2. [Check your Network settings.](#)
3. Files to be shared across the network should be placed in the D:\images folder. Once a file is saved to this folder, it can be accessed throughout the network, from any computer running any operating system; see [how do I access shared files.](#)

You will probably want to connect your printer to the same network. See your printer's documentation for further information.



→ [printing instructions](#)

→ [legal information](#)

© Copyright 2012, 2015 HP Development Company, L.P



## HP Pro Scanner

→ [how do I...?](#)

→ [the problem is...](#)

→ [alphabetical index](#)

## how do I make network settings?

These actions will make your system recognizable to others on the network.

**NOTE:** If the Administrator password has been setup and activated, you will be prompted for it before being able to make the network settings.

### to make your system's network settings...

1. Select the Setup Tab.
2. Select  > System.
3. Select the Advanced button.
4. Enter the Administrator password if prompted by the system.
5. Press the Network Settings button.
6. Select the DHCP option if you know that your network has a DHCP server. This will let the system find the network connection information automatically.
7. Select the Manually option for manual connection. Obtain the IP address, and other relevant network connection information from your system administrator.
8. Click OK for each setting.
9. You can protect your system's shared folders from unwelcome network access by applying a **login and password** under the **FTP and WebDAV** option area. Click the Login and Password buttons to enter strings and apply them.  
**Note** that the string "@scanner" is always appended to the entered login name.

Pressing the **Reset** button will remove login/password protection for FTP/WebDAV access and thereby bring the system back to its default mode (unprotected access to the system's shared folders).



[→ printing instructions](#)

[→ legal information](#)

© Copyright 2012, 2015 HP Development Company, L.P





## HP Pro Scanner

→ [how do I...?](#)

→ [the problem is...](#)

→ [alphabetical index](#)

## how do I change the default Administrator Password?

The Administrator password can be used to protect the setting of system specific options such as [interface language](#), [network parameters](#), [accounting](#) i.e., key administrative settings. Your system comes with a **default Administrator password - "hpinvent"** (all low-case letters).

**If the default Administrator password is equal to "hpinvent"** i.e., never changed or has been reset to its original value, password protection will not be applied to the key administrative settings and they will remain open for editing by all users.

**If the default Administrator password is changed** to something different than the default password "hpinvent", the system's key administrative settings will be protected and users will be prompted for the new password before they can enter the options for changing them.

If there are many who share the system, it is recommended that the default password is changed by the system's administrator when the system is setup the first time.

### to change the default Administrator password...

1. Select the Setup Tab.
2. Select  > System.
3. Select the Advanced button.
4. Select the Security Setup button.
5. Press the Set/Change Password button.
6. Enter the new Administrator password.
7. You will be asked to confirm the new Administrator password.
8. Click OK when finished. The new Administrator password is effective immediately.
8. You can turn off protection again by resetting the Administrator password to the default password "hpinvent".



→ [printing instructions](#)

→ [legal information](#)

© Copyright 2012, 2015 HP Development Company, L.P



## HP Pro Scanner

→ [how do I...?](#)

→ [the problem is...](#)

→ [alphabetical index](#)

## How do I set scan options and preferences

### scan options

Press the Setup Tab >  > Scanning to reach the Scan Options dialog.

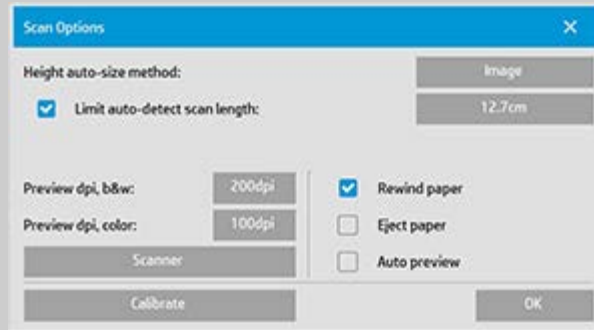

Tell me about the options...

...[preview dpi](#)

...[eject paper](#)

...[auto preview](#)

...[scan speed - fix backups](#)

...[rewind paper](#)

...[hight auto-size method](#)

...[limit auto-detect](#)

### preview dpi

Setup Tab >  > Scanning > Preview dpi

Determine the image resolution (between 50 and 300 dpi) for on screen previewing. Lower resolutions give faster previewing.

### eject paper

Setup Tab >  > Scanning > Eject paper

Use this option to make the scanner eject the paper automatically after each scan.

### auto preview

Setup Tab >  > Scanning > Auto preview

Use this option to automatically run a preview of the output as soon as an original is loaded in the scanner.

### scan speed - fixing backups

Setup Tab >  > Scanning > Scan speed

Sometimes, the performance of your workstation will cause the scanner to make repeated "back-ups" during scanning in order to ensure correct and continuous processing of scanned data. Back-ups can be avoided by reducing the maximum scanning speed thus refitting the scanner's performance to that of your workstation. The Default button can be used to restore the default scan speed value.

### rewind paper

Setup Tab >  > Scanning > Rewind paper

After scanning, your original will normally be found hanging at the back of the scanner. If the scanner is placed close to a wall, it may be difficult to access the original in order to remove it from the scanner. However, if the Rewind Paper option is selected, the original will be rewound back to its starting position after scanning. In this case, it can be ejected and removed from the front of the scanner.

### height auto-size method

Setup Tab >  > Scanning > Height auto-size method

There are two methods the scanner software can use to detect the height (length) of the image: Paper detects the end of the paper by mechanical means, while Image performs a prescan of the image and uses software to work out the length of the prescanned image. The Paper method is quicker because it doesn't require a prescan; but the Image method may be more accurate (if the paper is longer than the image).

### limit auto-detect scan length

Setup Tab >  > Scanning > Limit auto-detect scan length

This option is provided so that you can set a maximum to the auto-detected length of an image.



[→ printing instructions](#)

[→ legal information](#)

© Copyright 2012, 2015 HP Development Company, L.P



## HP Pro Scanner

→ [how do I...?](#)

→ [the problem is...](#)

→ [alphabetical index](#)

## how do I print on multiple printers?

If you are using the Copy tab or the Print tab to print sets or multiple copies, you can save time by printing on more than one printer at the same time.

Each copy or set will be printed on a single printer, but the printer will automatically allocate different copies or sets to different printers in order to print the whole job as quickly as possible.

Example 1: You have defined 3 synchronous printers and wish to print 3 different large format files that are in your print list, you can send the print job and the system will allocate a synchronous printer for each file so they can be output simultaneously.

Example 2: You have defined only 2 synchronous printers and are printing a set of four posters three times, each of the four posters will be printed twice on one printer (total: eight posters) and once on the other printer (total: four posters).

### to use multiple printers...

1. Select the Setup tab.
2. Select the Printer button.
3. Select the Tool button and then the Synchronous Printers button.

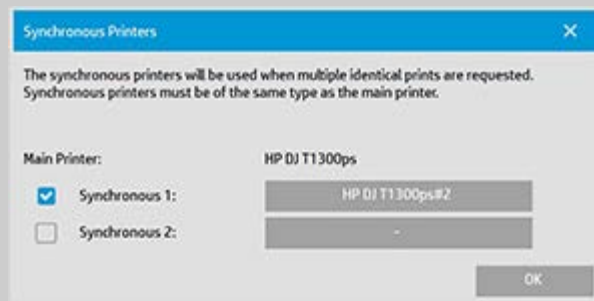

4. The main printer will always be your first printer. You can then select one or two additional printers (maximum 3 printers) for synchronous output together with the "Main" printer. Press the synchronous 1, 2 buttons to add printers.

*NOTE: Synchronous printers must be of the same model as your main printer.*

*NOTE: All printers must already be specified using Setup Tab > System > Install Printer Drivers and Setup Tab > Printer >*



*Tool button > Printer Setup.* See also [How do I install the printer and printer drivers?](#)



→ [printing instructions](#)

→ [legal information](#)

© Copyright 2012, 2015 HP Development Company, L.P



## how do I access shared files from another computer?

### HP Pro Scanner

→ [how do I...?](#)

→ [the problem is...](#)

→ [alphabetical index](#)

The following instructions explain how to access the shared files folder on your HP Scanner system from other computers on the same network.

To access shared files you will need to know:

The **IP address** of your HP Scanner system.

The system administrator may have applied protection for shared file access. If this is the case you will also need:

2. the **Login and password for FTP/WebDAV access**.

You can download files from the shared folder simply by entering the IP address into a Web browser's address field. You will be prompted for the FTP/WebDAV access login and password if protection was applied by your system administrator.

---

### For setting up general access from a computer on the network:

1. You need to make settings on the computer that you wish to use to access the shared files folder on your HP Scanner system. The computer must be on the same network as your HP Scanner system.
2. Open the computer's folder sharing options dialog.
  - On **Windows**: *Map Network Drives - Connect to a website...* option.
  - On **Mac**: *Connect to server* dialog
3. Follow the instructions on your screen. When prompted, enter the URL of the shared files folder on your HP Scanner system, which is **http://scanner\_ip/images**, where *scanner\_ip* is the IP address of the scanner system (see below about how to obtain the IP address).
4. Save your settings on the network computer.

---

**To obtain the IP address** information directly from the system:

**NOTE:** If an **Administrator password** has been setup and activated, you will be prompted for it before being able to enter the "Advanced" dialog



to view the IP address information directly from the system as described below.

Contact your system's administrator for the IP address information. If you are prompted for the administrative password and do not know it.

1. Select the Setup Tab
2. Select  > System > Advanced button
3. Enter the administrative password if prompted.
4. Press the Network Settings button to view the IP address information

---

**Administrators** - See "[How do I make network settings](#)" for details on how to protect the system from network access by setting a login and password

**NOTE:** You can also access shared files through **FTP protocol**. For this you will need the same information as stated above - i.e., the **IP address** of your HP Scanner system and the **login and password** for FTP/WebDAV access if protection was applied. You will also need a FTP client program.





## the problem is I get a system warning message

### HP Pro Scanner

- [how do I...?](#)
- [the problem is...](#)
- [alphabetical index](#)

### if you get a system message

1. The message will tell you how to proceed.
2. Follow the instructions in the "how do I...?" topics related to the message:

[How do I change replaceable scanner parts.](#)

[How do I run Calibrate](#)

See also:

[How do I view system messages](#)



→ [printing instructions](#)

→ [legal information](#)

© Copyright 2012, 2015 HP Development Company, L.P



## How do I ... view system messages

### HP Pro Scanner

→ [how do I...?](#)

→ [the problem is...](#)

→ [alphabetical index](#)

This dialog shows messages about the scanner or printer and contains the function for starting the Calibrate program.

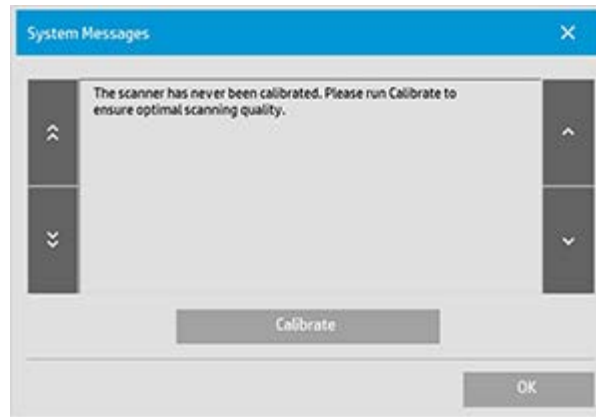

System messages will appear automatically on your screen one time only. After that, they can be recalled by **pressing the red "System Messages (press here)" text on the status bar** (screen's lower left).

A system message will tell you how to proceed in order to resolve the problem it is reporting on.

### Calibrate Button:

Most scanner problems can be resolved by running Calibrate. Press this button to start the camera alignment or full calibration process.





## HP Pro Scanner

→ [how do I...?](#)

→ [the problem is...](#)

→ [alphabetical index](#)

## how do I replace scanner parts? - HP HD Pro Scanner

**The following instructions apply for the scanner model HP HD Pro Scanner only** (see your documentation to identify the scanner model on your system).

On the HP HD Pro scanner, you can replace various scanner parts that are liable to wear down over long-term use.

Changing these parts will renew your scanner and ensure optimal results.

Before replacing parts, you should clean the scan area as described under [scanner maintenance](#) to see if any errors or image defects then disappear.

Select a topic:

[Replacing the glass plate](#)

[Replacing the white background platen](#)

[Replacing the scanner lamp](#)

### Replacing the glass plate

Small scratches on the glass plate can reduce scanning quality. Replacement with a new glass plate can be recommended by the program. Before replacing the white background platen, you should try to clean glass plate to see if errors or image defects then disappear.

To replace the glass plate:

1. Turn the scanner power off and disconnect the power plug. Push down on the lid release buttons to open the scanner lid and expose the glass plate.

### 2. Pull back the glass plate levers

- a. Locate the glass plate levers - on each side of the glassplate there is a small lever with a round lever-knob on its inner-end.
- b. Place a finger on both of the round lever knobs on each side of the scanner

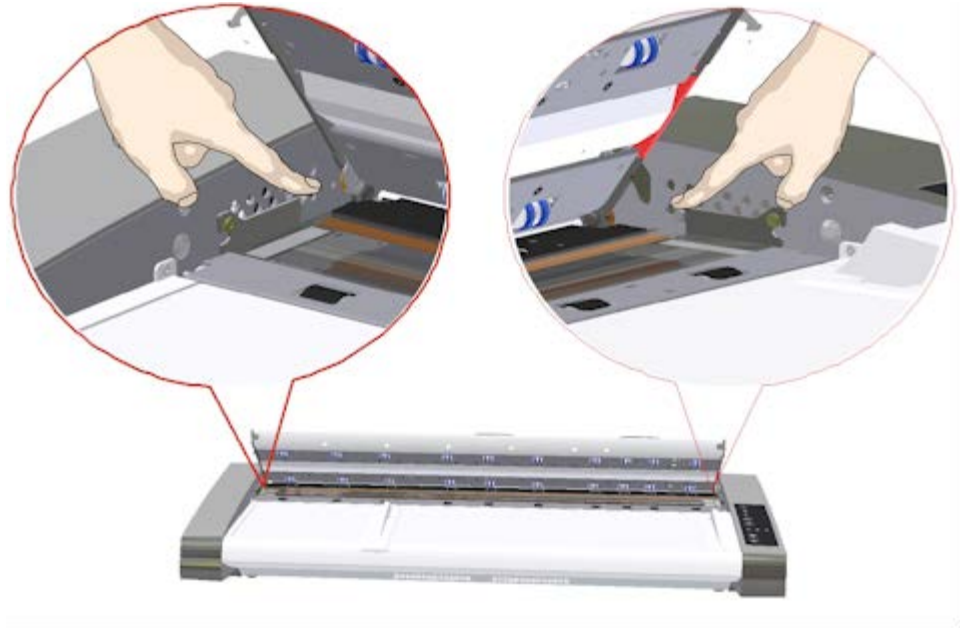

### 3. Tilt the glass plate back

At the end of each glass plate lever there is a small hook that rests on a round pin. The hook holds the glass plate in place on the scanner's chassis while also letting you un-attach the glass plate from the scanner. You start by tilting the glass plate upwards on the round pin's axis.

a. With both arms, pull simultaneously on the left and right levers to tilt the glass-plate towards your body on the round pin's axis.

b. Tilt the glass plate back on the hooks until it is completely free of its resting place on the scan area bed and you can access the glass plate edges.



#### 4. Lift the glass plate from the scanner bed

- a. Tilt and lift the glass back until the hooks become free of their pins.
- b. Lift the glass plate from the scanner..



#### 5. Insert a new glass plate

Reverse the above operations to reinsert a new glass-plate – Carefully set the new glass plate down into the scan area.

- a. Fit the new glass-plate's lever hooks on to the round pins on each side of the scanner.
- b. While supporting the glass-plate with fingers on the lever handles, carefully ease the glass-plate down backwards (away from your body) so it falls into place.
- c. Close the scan area lid.

NOTE: It is recommended to clean the new glass-plate after inserting it in the scanner and before scanning.

NOTE: It is recommended to recalibrate after changing the glass-plate..

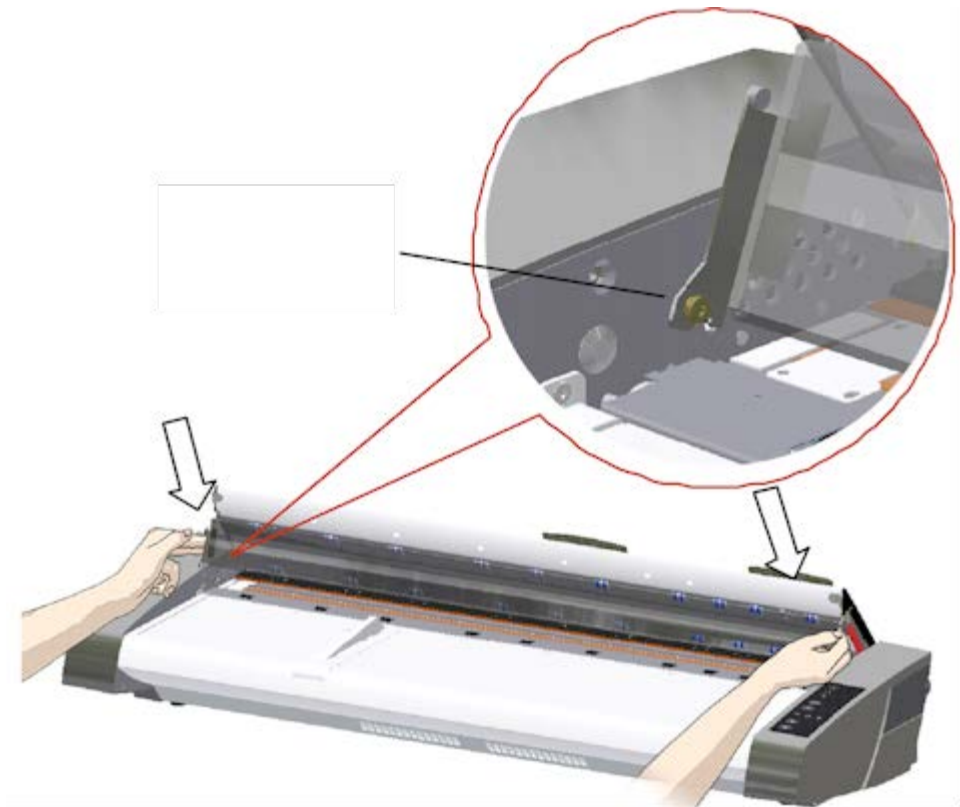

### Replacing the white background platen

A white background platen can become worn and discolored after long periods of use and in such cases replacement with a fresh white background platen is recommended. Before replacing the white background platen, you should try to clean it to see if errors or image defects then disappear.

To replace the white background platen:

1. Turn the scanner power off and disconnect the power plug. Push down on the lid release buttons to open the scanner lid.
2. On the lid's right edge, you will find a red strip. Remove the red strip to expose the edge of the white background platen.

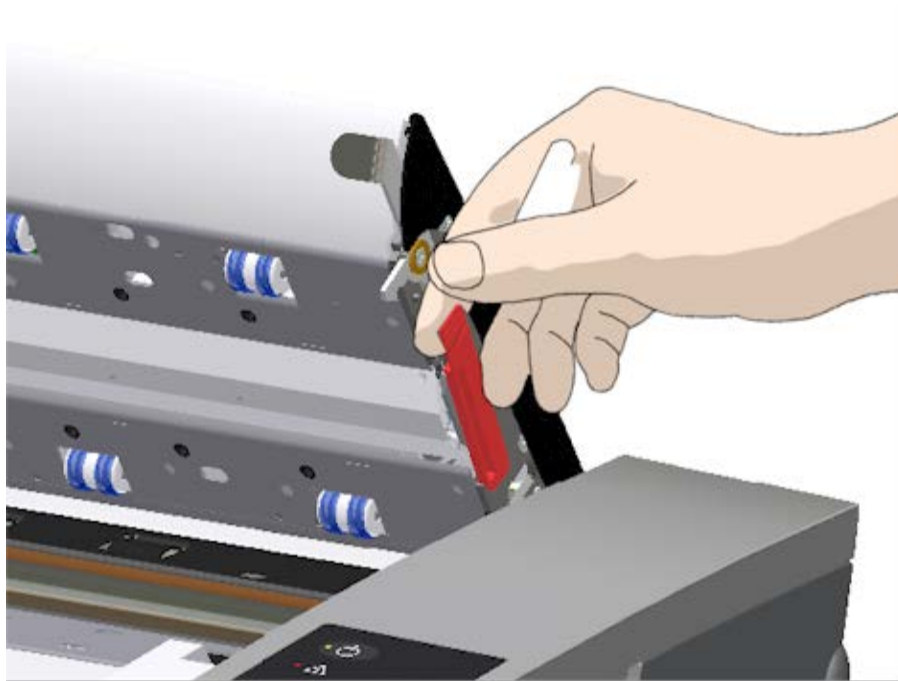

5. Grip the edge of the white background platen with your fingers and pull to slide it out of the scanner.



6. Slide in the new white background platen.
7. Reattach the red strip.
8. Close the scanning area lid so the locking mechanism reengages.

## Replacing the scanner lamp unit



Lamp effectiveness will gradually weaken over time. Replacement of the lamp-unit (lamp, reflector, power connectors) is recommended after long term use. Before replacing the lamp, you should clean the scan area as described under [scanner maintenance](#) to see if any errors or image defects then disappear.

To replace the lamp unit:

1. Turn the scanner power off and disconnect the power plug.

2. The lamp cover is at the right edge of the scanner. Place a finger in the gap and gently pull back to free the lid. Pull the cover sideways and off its hinges to detach it. The edge of the lamp unit will now be accessible.

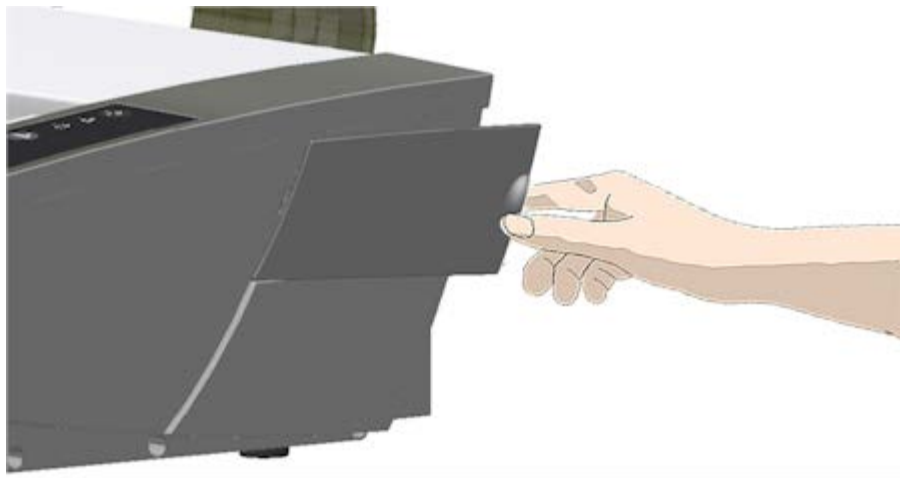

3. You must replace the whole lamp-unit. A lamp-unit consists of a lamp mounted in a reflector brace and fixed power connectors. At the visible edge of the lamp unit there is a handle. Grasp the handle with your fingers and carefully pull the unit out of the scanner.

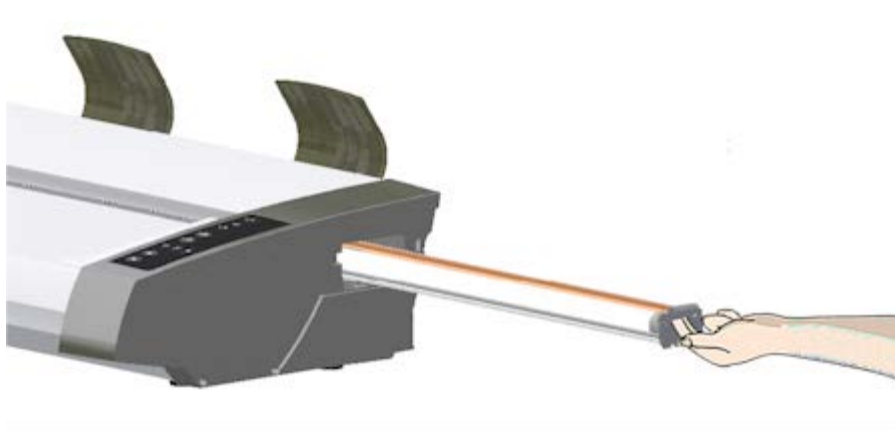

4. Reinsert the new lamp-unit by resting the power-connector side on the slider and carefully push the lamp-unit into the scanner.

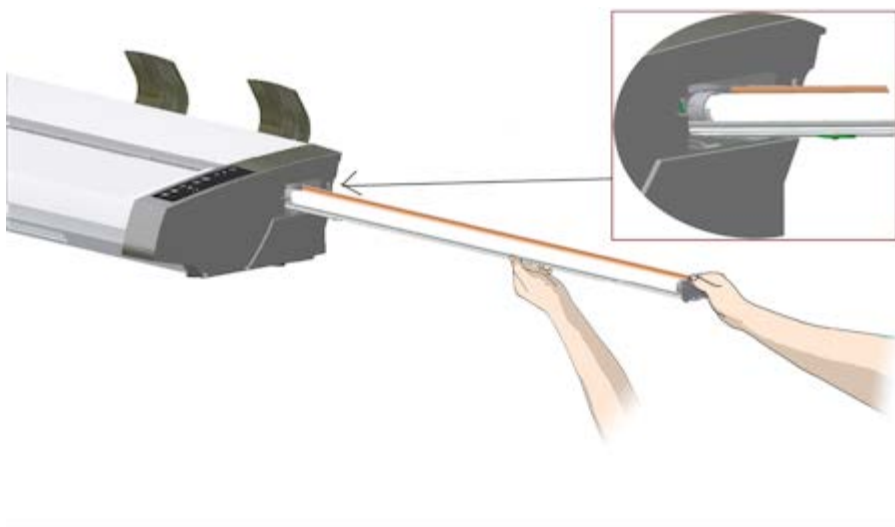

5. Insert the lamp-unit all the way so the internal power connections engage with the connections on the lamp-unit.
6. Replace the lamp cover on the scanner - fit the covers left side tab with the corresponding notche on the scanner and snap the cover shut. The cover must always be closed before turning scanner power ON.
7. Test the replacement by turning power and scanner on to see if the lamp lights.
8. NOTE: Remember to reset the lamp replacement flag in WIDSystem.



→ [printing instructions](#)

→ [legal information](#)

© Copyright 2012, 2015 HP Development Company, L.P



## HP Pro Scanner

→ [how do I...?](#)

→ [the problem is...](#)

→ [alphabetical index](#)

## how do I replace the glass plate? - HP SD Pro Scanner

**The following instructions apply for scanner model HP SD Pro Scanner only** (see your documentation to identify the scanner model on your system).

Small scratches on the glass plate can reduce scanning quality. Replacement with a new glass plate can be recommended by the program.

You can replace the glass on your HP SD Pro Scanner.

### Replacing the glass plate

#### 1. Power off and open the lid

Turn the scanner power off and disconnect the power plug. Open the scanner lid by pushing the 2 backside lid release buttons towards the middle of the scanner

#### 2. Identify the latch release buttons

The illustration below shows the scanner from above with its lid open. The illustration indicates the key parts and buttons you need to recognize when replacing a worn glass plate.

The glass plate is held and locked in place with 2 small white-colored latches. Each latch can be released from the glass plate by pressing down on its corresponding latch release button (see illustration below). Each latch release button is placed in a square hole just under the latch it releases.

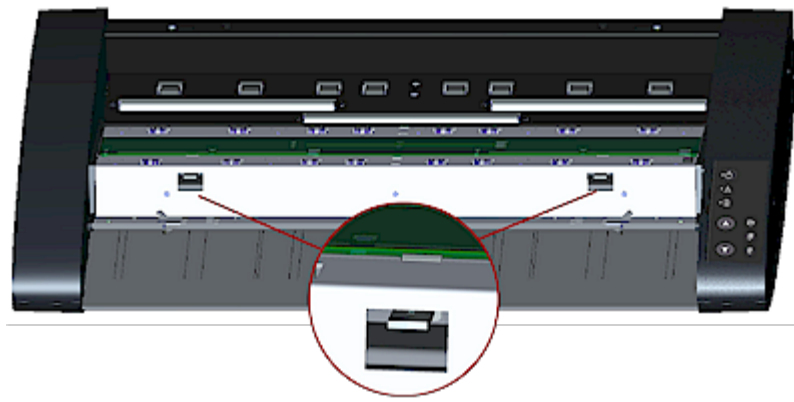

### 3. Detaching the glass plate – free the 1st latch

Stand at the front of the scanner. You start at the scanner's right side. See the illustration below.

- a. Detaching the first (rightmost) latch requires a sharp, flat tool such as a pen or a small screwdriver.  
NOTE: Detaching the remaining latch will not require use of a tool.
- b. Locate the arrow label at the scanner's right side.
- c. Position the tool just under the glass plate edge where the arrow label indicates. At the same time; press down on the latch release button in the first (rightmost) square hole.
- d. Carefully, use the tool to flip the edge of the glass upwards until it comes above and free of the white latch that held it down.
- e. Release the latch release button.

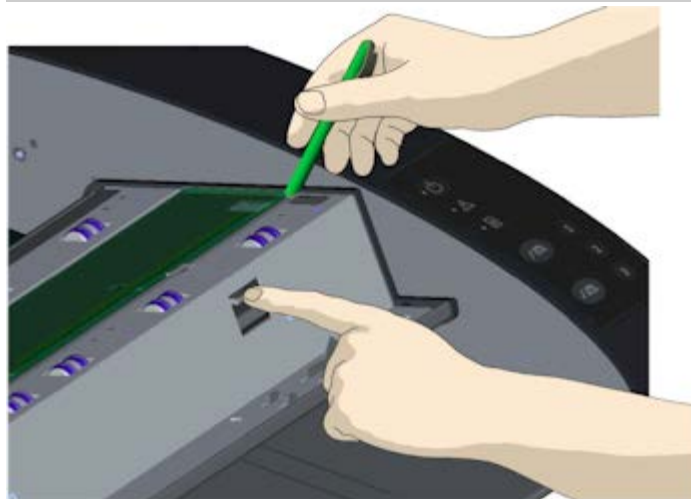

### 4. Detaching the glass plate – free the 2nd latch

After freeing the first latch in the previous step, freeing the 2nd

latch is easy. See the illustration below.

- a. Press down on the latch release button in the 2nd square hole.
- b. The 2nd latch will release its grip and the glass will pop up over the latch.

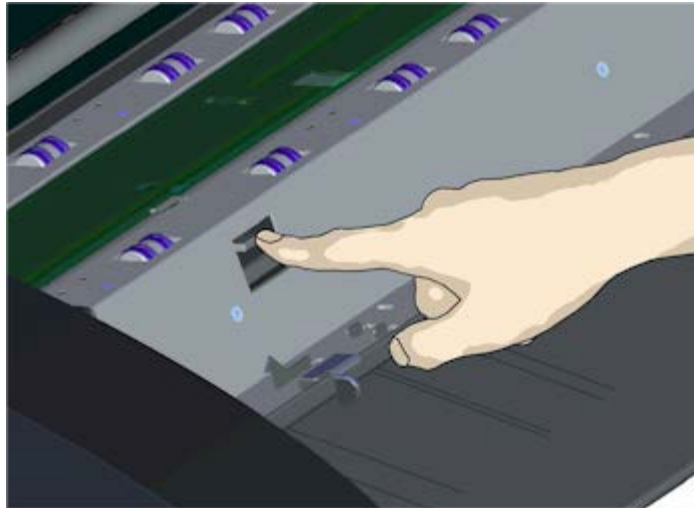

#### 5. **Detaching the glass plate – Tip the glass plate edge upwards**

After releasing the latches, the glass plate is now free for removal.

- a. Stand at the front side of the scanner.
- b. Insert your thumbs under the glass plate edge around the middle area as shown in the illustration on the right.

NOTE: If you can't get your thumbs under the glass - use the sharp, flat tool from step 5 to tip the glass high enough to get a thumb underneath.

- c. Tip the glass back and up so its two ends are free.
- d. Move your hands, one at a time, to each end of the glass.
- e. Apply light pressure with each hand as you lift the glass out of the scanner.

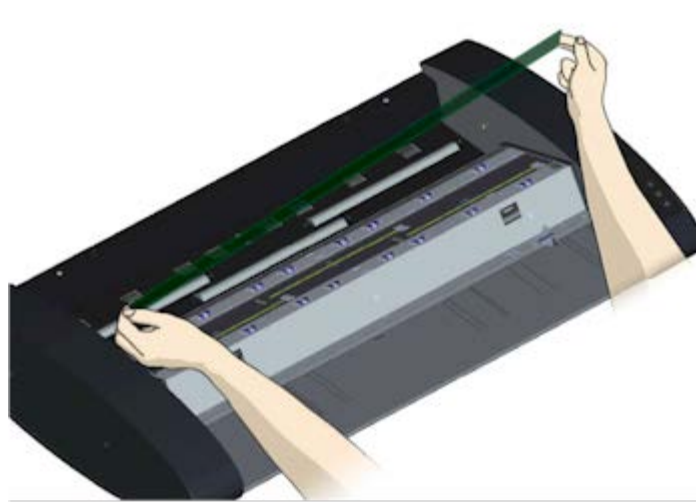

**6. Insert a new glass plate – lower a new glass plate into the scanner**

a. Pick up the new glass plate in the same manner as you removed the old one - with two hands holding the glass on each end so you avoid touching the glass surface.

NOTE: Take special care to avoid touching the glass plate's bottom surface which normally will not be cleaned during maintenance.

b. Stand at the front of the scanner as you hold the glass. Make sure you hold the glass for insertion with the correct surface facing down. Note the direction of the faceted edges that indicate which is the bottom surface of the glass. See the illustration of the glass plate's profile below. 1.=Top surface, 2.= Bottom surface

c. Hold the glass so that the bottom side surface faces your body as indicated in the glass plate's profile view below.

d. Lower the new glass plate into the scanner at an angle, as shown in the glass plate's profile view below, so that the glass's lower edge meets the scanner's bottom position groove.

CAUTION: The glass plate is long and thin and thus fragile. Take care not to break it.

The glass plate will rest in the scanner's lid between the bottom and top position grooves. Locate the glass plate's bottom position groove in the lid. This is the groove furthest from your body when you stand at the scanner's front.

f. Place the lower edge of the glass plate so it rests in the glass plate's bottom position groove.

g. Carefully tilt the upper edge (the edge closest to your body)

down until the glass plate rests in the scanner lid between the 2 grooves (top/bottom position grooves).

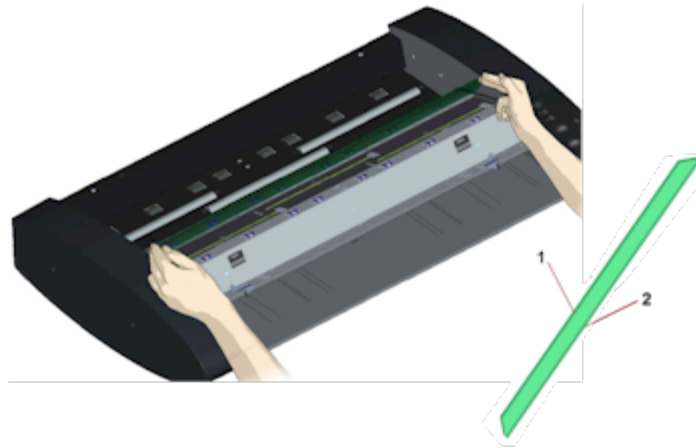

### 7. Lock the new glass plate in place

The glass needs to be locked in place with the two latches. At this point, the latches are under the glass plate and they need to be brought above so they grip the glass plate's edge.

- a. Start at the right side.
- b. Press down on the first (rightmost) latch release button.
- c. With your other hand, press down on the glass plate near the latch so the glass plate's edge snaps down under the latch.
- d. Repeat the process with the other latch.
- f. Ensure that both latches are gripping the glass plate's edges.

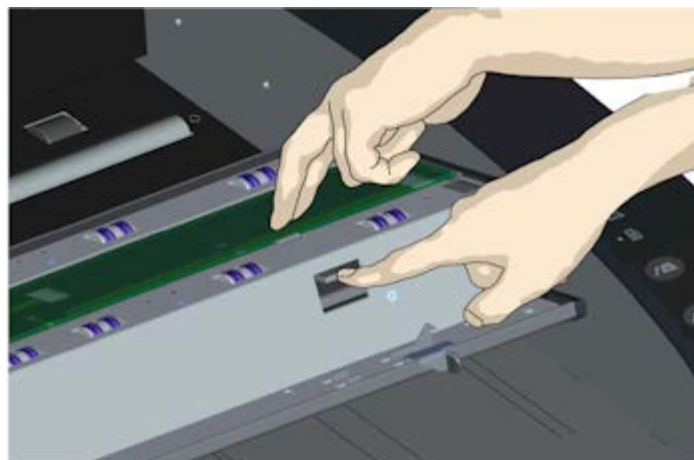

### 8. Clean the new glass plate



Make sure you use 2 fresh and clean lint-free cloths for cleaning your new glass plate.

a. Spray/apply a mild, streak-free, glass cleaner onto a lint-free cloth.

b. Gently wipe the glass clean. Look for fingerprints and smudges that may have been applied to the glass during replacement.

c. Dry the glass completely using the other clean, dry lint-free cloth.

d. Make sure that fluids do not get under the glass and that you leave the area dry.

**CAUTION:** Do not spray/apply cleaner fluids directly on the glass plate or anywhere else in the scan area.

e. When done, close the lid gently until you hear the lid locks click.





## HP Pro Scanner

→ [how do I...?](#)

→ [the problem is...](#)

→ [alphabetical index](#)

## how do I set system date and time?

The date and time can be set so they will be known by the program. Setting the date and time is relevant for accounting.

### setting the date and time

1. Press the Setup tab.
2. Press  > System
3. Press the Set Time and Date button
4. Start with the Time Zone setting. Press the Time zone button and select the time zone for your area.
5. For convenience, you can select automatic daylight savings time adjustment.
6. With the local time zone selected, set the current date and time. Press each value button to make a setting. You will need your keyboard to set values.



→ [printing instructions](#)

→ [legal information](#)

© Copyright 2012, 2015 HP Development Company, L.P



## HP Pro Scanner

- [how do I...?](#)
- [the problem is...](#)
- [alphabetical index](#)

## how do I view the print queue?

With some printers, your system will have a Print Queue button at the bottom of the main screen.



Press the button to view the current printers job queue.

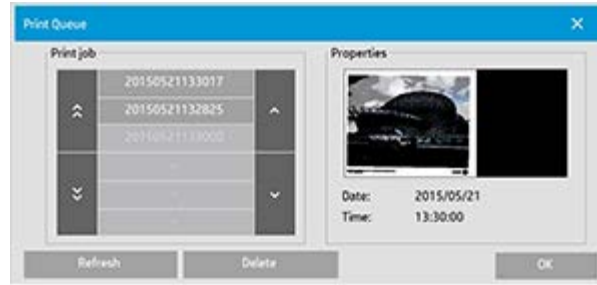

## to view the print queue

Press the Print queue button at the bottom of the screen.



The print queue list dialog lets you manage any jobs still waiting to be output. You can move through the list and Delete unwanted jobs.

The print queue dialog's Properties section contains a window for previewing the job you select in the queue list and additional information.

Note : This function is not available with all printer models.





## HP Pro Scanner

→ [how do I...?](#)

→ [the problem is...](#)

→ [alphabetical index](#)

## how do I scan to and access a network folder?

Per default, your system's folder browse dialogs will display only local drives and folders. This topic explains how you can add network locations to the system. Once added, you can use a network location and underlying folders as destinations for [scan-to-file \(Scan tab\)](#) jobs and access them with the [file manager \(folder button\)](#).

### To add/store/remove a network connection

1. Your system must be connected to the network.
2. Press the folder button to open the file manager dialog.  

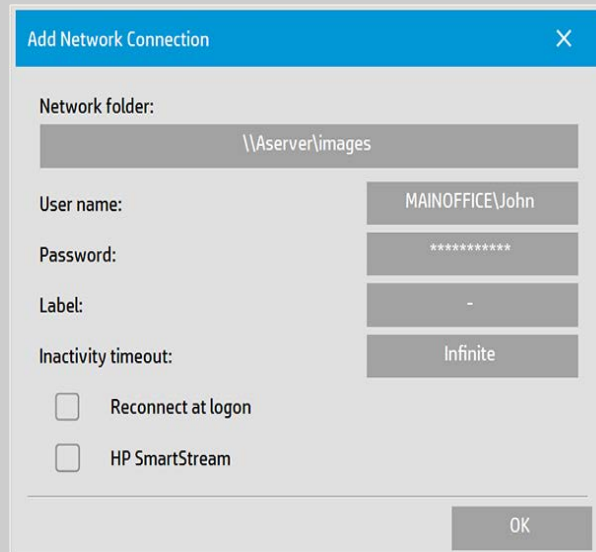
3. Press the "Network" button.
4. Press the Add Network Connection button to open the dialog shown below. Contact your network administrator if you need information about one or more of the dialogs settings as described in the next steps.



5. Network Folder – enter the full path name to the location on the network. This can be a server name, an IP address or any name that is recognized by the network and identifies a valid connection/location.
6. User name – the login user name for the network server/ machine. If your your machine is on a network Domain, then you need to write the combination:  
<domain name>\<user> in the field. Example:  
"MAINOFFICE\John".

7. Password - the login password for the network server/ machine.
8. Label – this is what your HP Scanner system will display in its browse dialogs. Enter a name that will help you identify the network destination.
9. Inactivity timeout – This feature enables you to set an individual timeout value (in minutes) for your network connections, for added security.  
**NOTE:** "If timeout value is set to 0 (Infinite) then the network connection will never time out. See more in: [How does the Inactivity timeout for a network connection work?](#)
10. Reconnect at logon – If this is left unchecked, your network connection definition will automatically be deleted when you shut down the panel PC. Select this option to tell the system to store the connection and activate it every time you start up the system.  
**NOTE:** "Reconnect at logon" is a user feature. The option will only be visible if it is enabled by the system's administrator. See more in: [How do I enable storing of network connections?](#)
11. HP SmartStream – Select this option to identify the added network location as an HP SmartStream hot-folder.  
**NOTE:** The same network location needs to be added as a hot folder in HP SmartStream preferences.

**NOTE:** You can add as many network connections as you need. However, system will not allow 2 or more network connections on the same server with different users. Example:

If user "John" has created the network connection:  
"\\server1\colorphotos"

Then user "Judy" (or other users) cannot create the network connection:  
"\\server1\pdffiles"

...the system will reject the action.

### **Removing network connections:**

**Manual removal:** You remove network connections through the

Folder button  > Network > "Remove Network/FTP Connection".

**Automatic removal:** If a network connection definition is not stored

(see above) it will be deleted **automatically** when you shut down the panel PC.

Stored connections must be removed manually. You may for example wish to remove a stored network connection that fails at system startup because the server status or permissions have changed.

### To scan to the network folder

1. Complete the steps above under "To add a network connection".
2. Select the Scan tab and make your settings as with any scan-to-file job.
3. Press the "File destination" button.
4. Press the path up ("..") button until it disappears meaning you reached the list's topmost level which is the list of accessible drives.
5. Navigate the list until you see your network location i.e. the Label you entered in step 8 under "to add a network connection" above.
6. Select the network location.
7. Once connected, you can navigate to a folder under the network location to select it as the destination.
8. Press OK when you have highlighted the destination folder you want to use.

### To access files on the network folder

1. Complete the steps above under "To add a network connection".
2. Press the folder button to open the file manager dialog.



3. Press the path up (“..”) button until it disappears meaning you reached the list’s topmost level which is the list of accessible drives.
4. Navigate the list until you see your network location i.e. the Label you entered in step 8 under "to add a network connection" above.
5. Select the network location
6. Navigate to the folder under the network location you wish to access.
7. Press OK when you have highlighted the file you want to open.

## How does the Inactivity timeout for a network connection work?

1. When a network connection is added then it is possible to specify an inactivity timeout for security reasons. If timeout value is set to 0 (Infinite) then the network connection will never time out.  
See more in: [To add/store/remove a network connection](#)
2. The Network Logon dialog below will be displayed if inactivity period is reached and access to a network connection is

Network Logon

Network folder:  
\\Aserver\images

Label:

User name: MAINOFFICE\John

Password: \*\*\*\*\*

Inactivity timeout: Infinite

OK

attempted.

3. In the Network Logon dialog you will be able to change User name, Password or Inactivity timeout value.

**NOTE:** Password is mandatory and should always be entered to

reestabilsh network connection.

4. Press OK to connect when you have changed credentials or timeout value.



→ [printing instructions](#)

→ [legal information](#)

© Copyright 2012, 2015 HP Development Company, L.P





## HP Pro Scanner

→ [how do I...?](#)

→ [the problem is...](#)

→ [alphabetical index](#)

## how do I scan to an FTP server?

Per default, your system's folder browse dialogs will display only local drives and folders. This topic explains how you can scan to an FTP server on the network. Once added, you can use this destination for [scan-to-file \(Scan tab\)](#) jobs.

### To add/remove an FTP connection

1. Your system must be connected to the network.
2. Press the folder button to open the file manager dialog.  

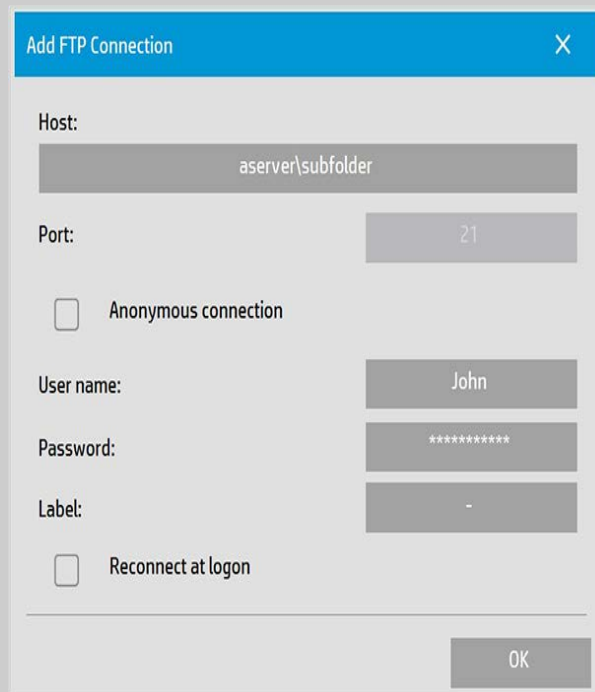
3. Press the "Network" button.
4. Press the Add FTP Connection button to open the dialog shown below. Contact your network administrator if you need information about one or more of the dialogs settings as described in the next steps.



Host: aserver\subfolder

Port: 21

Anonymous connection

User name: John

Password: \*\*\*\*\*

Label: -

Reconnect at logon

OK

5. Host – enter the full path name to the location on the FTP server, including the subfolder.
6. User name – the login user name for the FTP server. Example: "John".

7. Password - the login password for the FTP server.
8. Label – this is what your HP Scanner system will display in its browse dialogs. Enter a name that will help you identify the FTP destination.

**Remove FTP connections :** You remove FTP connections through the Folder button  > Network > "Remove Network/FTP Connection".

### To scan to the FTP server

1. Complete the steps above under “To add an FTP connection”.
2. Select the Scan tab and make your settings as with any scan-to-file job.
3. Press the "File destination" button.
4. Press the path up (“..”) button until it disappears meaning you reached the list’s topmost level which is the list of accessible drives.
5. Navigate the list until you see your FTP location i.e. the Label you entered in step 8 under "to add an FTP connection" above.
6. Select the FTP destination.
7. Press OK when you have highlighted the destination folder you want to use.

**NOTE:** All scans will be saved directly in the FTP server (or subfolder) you have specified while creating the FTP connection. You cannot perform file management tasks on the FTP connections (deleting files, creating subfolders, etc.).





## HP Pro Scanner

→ [how do I...?](#)

→ [the problem is...](#)

→ [alphabetical index](#)

## Getting Started with your HP Pro Scanner

Congratulations on choosing the HP Pro Scanner.

This help page will guide you through the necessary final steps to get your system running.

After completing these steps, you can use this help system to find answers to any questions about operation.

### Getting Started involves the following steps:

1. [Install your printer and printer drivers.](#)
2. [Run Calibrate.](#)
3. [Create a Media Profile.](#)

**About viewing instructions in the help system:** You do not need to print this page. While viewing a help topic, you can press the HIDE button to close the help window, freeing the whole screen for carrying out the Getting Started instructions. The system will remember your last help topic and it will reappear on your screen when you press the ? button once again.



**After completing these steps,** you can use this help system to find answers to any questions on operation. Go to the help [welcome page](#) for information about using this help system.

### step 1: install your printer and printer drivers

Your HP Scanner system must recognize the printer before the scanner, software and printer can operate together.

Your printer must be connected through the LAN and the right driver is selected and installed during setup.

Follow the link below for instructions on setting up your printer and printer drivers.

1. [Install your printer and printer drivers.](#)

## step 2: run Calibrate

Preliminary Calibrate will ensure correct and reliable performance from the start. After shipping, unpacking and setting up your scanner, it must be cleaned and calibrated before using it the first time. After that, scanner maintenance on a regular basis will ensure stable and reliable results with every job.

1. [View the full instructions for Calibrate - cleaning and calibration.](#)

## step 3: create a media profile for your printer

A Media Profile is the unit that stores the data for matching scanner and printer colors on a given media. You must create a Media Profile for each media type you use with the specific color printer. Your new media profile(s) will be used for color copying. Before you start a copy job, you will select the media profile that corresponds with the media in your printer. By this action you are harmonizing scanner, printer and media factors for achieving matching colors between the original and its copy.

1. [...how do I... create a new media profile for my printer and media?](#)

Congratulations! You have now setup your HP Scanner system and are ready to make your first high quality copies.





## HP Pro Scanner

→ [how do I...?](#)

→ [the problem is...](#)

→ [alphabetical index](#)

## how do I use the Resize option to determine output size?

### to select the output size...

1. Press the Scan tab.
2. Press the Resize size button.

You can select one of the following options:

- None - No resizing. The output size will be equal to the input size.
- Size - Opens the Output Size dialog. Here you can set a custom size, a standard size. [Instructions](#).
- Scale - Opens the Scale dialog in which you can determine a scale factor. [Instructions](#)

See also:

...[how do I set the input size?](#)



→ [printing instructions](#)

→ [legal information](#)

© Copyright 2012, 2015 HP Development Company, L.P



## HP Pro Scanner

→ [how do I...?](#)



→ [the problem is...](#)

→ [alphabetical index](#)

## how do I optimize color accuracy?

Follow the guidelines below to ensure color accuracy.

### guidelines..

1. Make sure your scanner's glass plate and white background platen/white rollers are clean and you have recently performed scanner maintenance including cleaning and calibration. [View the Calibrate Instructions.](#)
2. Make sure your scanner has warmed up for at least one hour before copying - apply only for the HP HD Pro Scanner.
3. Do you have a media profile for the specific media type that is in the printer? If not, you will need to create a new media profile. [View the media profile creation instructions.](#)
4. Have you selected for the job the media profile that was created for the specific media in the printer? If not you have to select it through the Copy tab>Media Profile. [View the media profile selection instructions.](#)
5. Are you copying an original that was printed with this system or on another inkjet printer? If yes, than you must select the "Ink Printer Original" option in the Copy tab>  dialog or the Print tab >  dialog. [View instructions for making output quality settings.](#)
6. Are you copying a color map and some of the colors in the copy appear as gray? Make sure the "Enhance Gray" option under the type of original template is not selected. Copy tab>Type of original>Tool button>More>Enhance Gray  
See also: ...[to define an original template...](#)



→ [printing instructions](#)

→ [legal information](#)

© Copyright 2012, 2015 HP Development Company, L.P.



## HP Pro Scanner

→ [how do I...?](#)

→ [the problem is...](#)

→ [alphabetical index](#)

### the problem is that the image is not printed - job held in queue

If your printer does not start printing the image, the job may be held up in the print queue. With some printers you can view the printer queue to see if that is the case. To do so, press the Print queue button at the bottom of the screen.



There can be a number of reasons why the printer is holding the job and not printing. Check and fix any of the causes listed below:

#### if your job is held in the queue

1. The printer may hold the job if the media profile selected is not correct in relation to the media in the printer. If you find that the media profile setting is incorrect - see: [...how do I select a media profile](#).  
If you find that a media profile for the printer's current media does not exist in your system - See [... how do I create a new media profile](#).
2. The printer may hold the job if the output size width defined for the job is wider than the actual media roll width loaded in the printer. If this is the case - change the roll or the output size width.







## HP Pro Scanner

→ [how do I...?](#)

→ [the problem is...](#)

→ [alphabetical index](#)

## how do I batch copy and batch scan to file?

Batch copying and scanning involves processing a large number of originals in one session without readjusting parameters or repeated clicks on the Copy or Scan button.

With batch scanning, you can stand at the scanner and just load originals until you are finished. Batch scanning is useful with groups of documents that require equal settings.



You can perform batch scan to printer (Copy) or batch scan to file. Batch scanning with copying, i.e., direct scan to print is optimally used with fast printing documents such as B&W drawings.

**NOTE:** For HP PageWide printers the Batch scanning feature is by default enabled.

## ...how do I perform batch copying or scan-to-file

1. Prepare the originals you wished scanned with equal settings.
2. Load a representative original into the scanner.
3. Set up your parameters as with single-document scanning. For copying this is in the Copy tab and for scan-to-file in the Scan tab.

4. **If you are copying, select:**

Copy tab >  > Batch Scan and press OK. Press the copy button when ready 

NOTE: For the HP PageWide printers press the copy button



**For Scan-to-file select:**

Scan tab >  > Batch Scan and press OK. Press the scan-to-file button when ready.



5. The program will now run in Batch scan mode. You can feed originals and they will be saved or printed right away.

6. You can interrupt the batch scan mode by pressing the stop button.

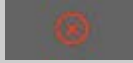

This means you can feed an original without its being scanned and saved right away. You resume Batch scanning the next time you press the copy or scan-to-file button.

7. The scanner remains in Batch scan mode until you cancel the Batch scan option through the settings button

**TIP:** You can set the scanner to eject the document on completion of each scan and thus clear the way for feeding the next document.

Set this option through the Setup Tab >  > Scanning > Eject paper

**TIP:** With batch scan to file - You can use automatic file naming. You define automatic file naming when you make your scan to file settings in the Scan Tab – File name field. [See the help topic how do I scan to a file?](#) for more details.





## HP Pro Scanner

→ [how do I...?](#)

→ [the problem is...](#)

→ [alphabetical index](#)

## how do I automatically align the image?

For best scanning results, the paper should be correctly orientated during insertion into the scanner so that it feeds on a straight path. However, slight deviations can occur when inserting large documents. These can be fixed electronically during scanning with the Auto Alignment option selected.

With Auto alignment selected, the application aligns the image during scanning based on features in the original image.

Auto Alignment can be applied with both Copying (from the Copy tab) and with Scan-to-file (from the Scan tab).

### ...how do auto align with copying or with scan-to-file

1. Insert the original into the scanner as evenly as possible.
2. Make all your settings for the job in the Copy tab or the Scan tab.
3. **If you are copying, select:**  
Copy tab >  > Auto align and press OK. Then press the copy button when ready.



#### **For Scan-to-file select:**

Scan tab >  > Auto align and press OK. Then press the scan-to-file button when ready.



#### **Disable the alignment option**

The alignment will be reset when the "Auto align" is un-selected. The alignment angle (both auto and manual) will be set to zero (no alignment).





## HP Pro Scanner

→ [how do I...?](#)

→ [the problem is...](#)

→ [alphabetical index](#)

## how do I mirror the image?

By selecting the Mirror option before pressing the copy or scan button, you can Mirror the image during scanning.

You can apply the Mirror option with both Copying (from the Copy tab) and with Scan-to-file (from the Scan tab).

### ...how do I mirror the image with copying and with scan-to-file

1. Insert the original into the scanner.
2. Make all your settings for the job in the Copy tab or the Scan tab.
3. **If you are copying, select:**  
Copy tab >  > Mirror and press OK. Then press the copy button when ready.



#### **For Scan-to-file select:**

Scan tab >  > Mirror and press OK. Then press the scan-to-file button when ready.





## HP Pro Scanner

→ [how do I...?](#)

→ [the problem is...](#)

→ [alphabetical index](#)

## how do I set the output margins?

You can set regular "Margins" and additional "Outer margins".

For both types you can define values for top, bottom, left, right.

**NOTE:** Margins are irrelevant for scan-to-file jobs. All margin values will automatically be set to zero when working from the Scan tab.

"**Margins**" are created within the selected scan area and thus replace edges of the image itself with white border of the breadth defined by the "Margins" values. ("cropping" the image).

The "Margins" values are deducted from the set Output size and thus the intended final copy size is retained.

With scaling, the actual margin values are applied to the printed result while the margin's cropping effect (breadth of cropping edges) on the scan area is adjusted according to the relation between the input size and output size (scaling value).

Without scaling (1:1 copying), the actual margin values are applied to the printed result and are equal to the breadth of the edges that crop the scan area.

See the [examples](#) for clarification.

The "**Outer margins**" option lets you add additional margins to the scan area, thus adding white border to the edges of the copy while leaving the scan area intact. The final copy size is thus extended in relation to the set output size.

The [examples](#) describe actual cases when applying margins and outer margins.

You can use "Margins" together with "Outer margins" to crop off unwanted edges. You can also crop off existing low quality (discolored, unsharp) margins and add new or additional white margins to the end result.

## ...how do I set margins?

"Margins" are for applying white border to the edges of the copy. The Margins replace edges of the image itself (scan area) with white border.

1. Select the Setup tab.
2. In the Setup dialog, press the Margins button. The Margins dialog is displayed:

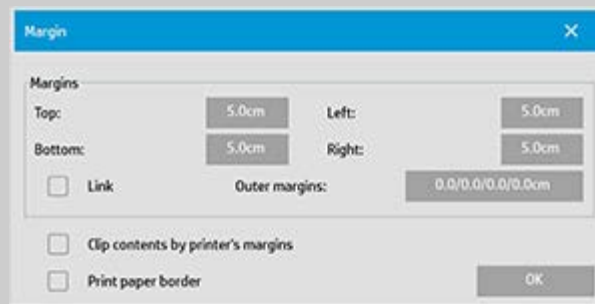

3. Set the Top, Bottom, Left and Right margins in the Margins dialog.
4. Use the "Link" option if you want equal margins all around the image. With the Link option checked, you only have to enter the margin value in one of the four fields.
5. Most printers cannot start printing at the very edges of the paper and thus enforce a margin on your output. You can choose to account for this enforced margin by enabling the "Clip contents by printer's margins" option. Read more about the ["Clip contents by printer's margins" option](#).
6. Check the Print Paper Border option to get a thin black line around the output size boundaries. With wide format printing on large printer rolls, this option will give you a clear cutting line so you end with precisely the output size you defined.
7. The breadth of the Paper Frame displayed in the Preview Window will reflect your margin settings in relation to the Output size while also accounting for the Input size (scan area) so you can see precisely how they will crop the input image. Press the Preview button to load a preview with visible Margins defined by your settings. If you set Margins to zero, then a thin frame will still outline your current capture area in the Preview Window.



## ...how do I use Outer margins?

"Outer Margins" are for adding white border to the edges of the copy while leaving the scan area intact.

1. Select the Setup tab.
2. In the Setup dialog, press the Margins button. The Margins dialog is displayed:

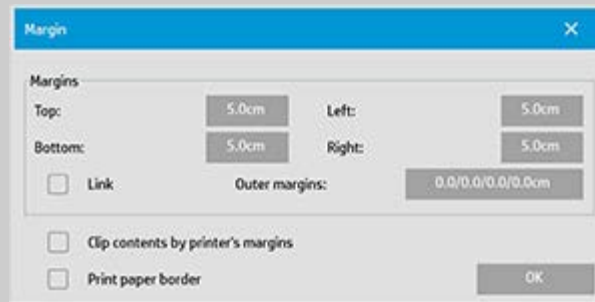

3. Press the Outer Margins button.
4. Set the Top, Bottom, Left and Right margins in the Outer Margin dialog.
5. Use the "Link" option if you want equal Outer margins all around the image. With the Link option checked, you only have to enter the Outer margin value in one of the four fields.
6. Most printers cannot start printing at the very edges of the paper and thus enforce a margin on your output. You can choose to account for this enforced margin by enabling the Margin dialog's "Clip contents by printer's margins" option. Read more about the ["Clip contents by printer's margins" option](#).
7. Check the Print Paper Border option to get a thin black line around the new output size boundaries. With wide format printing on large printer rolls, this option will give you a clear cutting line so you end with precisely the output size you defined.

## ...Examples of using Margins and Outer Margins

### Example1:

The Input size is: 10x10".

The Output size is 10x10" (no scaling)

Margins are set at: 1" at all edges.

Outer Margins are set at 0" at all edges.

Result: Total size 10x10", Scanned area 8x8", 1" white border at all edges.

Explanation: The margin of 1" is deducted from the scan area at all edges (all around) creating the 8x8" scan area. The total size is equal to the output size (and input size as there is no scaling) because white space border through the "Margins" setting is deducted from the output size and none is added on.

### **Example2:**

The Input size is: 10x10".

The Output size is 10x10" (no scaling)

Margins are set at: 0" at all edges.

Outer Margins are set at 1" at all edges.

Result: Total size 12x12", Scanned area 10x10", 1" white border at all edges.

Explanation: Margin is set to 0" so nothing is deducted from the scan area and the 10x10" scan area remains intact. The total size is 12x12" because the Outer margin is set to 1" and thus 1" of white space border is **added** to the output size at all edges (all around).

### **Example3:**

The Input size is: 10x10".

The Output size is 10x10" (no scaling)

Margins are set at 1" at all edges.

Outer Margins are set at 1" at all edges.

Result: Total size 12x12", Scanned area 8x8", 2" white border at all edges.

Explanation: The margin of 1" is deducted from the scan area at all edges creating the 8x8" scan area. The outer margin of 1" is added to this white space giving a total of 2" white border. The added "Outer margin" (and only the outer margin) of 1" expands the total output size by 1" around all the edges totaling to the 12x12" output result.

### **Example4:**

The Input size is: 10x10".

The Output size is 20x20" (2 x scaling)

Margins are set at 1" at all edges.

Outer Margins are set at 1" at all edges.

Result: Total size 22x22", Scanned area 9x9", 2" white border at all edges.

Explanation: Example 4 shows margin value application on the scan area (input) with scaling, i.e., when the output size is larger than the input size. As with the previous examples, the margin's value of 1" is still deducted from the output size and this 1" white space plus 1" outer margin will be output on the printer totaling to a 2" wide white border. However, because of scaling, the 1" margin that should be taken within the scan area during **input** is automatically reduced relatively (in this case by half since its a 1:2 relation) so that only 1/2"



is deducted from the scan area at all edges during input. In this way, cropping of the scan area is logically adjusted to fit the Margin that was defined for the enlarged end result and match normal intentions.



→ [printing instructions](#)

→ [legal information](#)

© Copyright 2012, 2015 HP Development Company, L.P



## HP Pro Scanner

→ [how do I...?](#)

→ [the problem is...](#)

→ [alphabetical index](#)

## how do I input in portrait and output in landscape?

The "Auto Landscape" option is useful when you want your copy output in landscape but inputting the original in landscape with the scanner is not possible because the scanner is too narrow and you can only insert the original with portrait (short edge forward) orientation.

NOTE: The process of rotating the image is time and resource consuming. Therefore, use this option only when you cannot insert the original in landscape.

## ...how do I set Auto Landscape?

1. Select the Copy tab.
2. In the Copy tab, press  and the following dialog is displayed:



3. Press the Rotation button and select "Auto Landscape"  
Press OK to save and exit
4. When Auto landscape is active it rotates the output 90 degrees. This happens only when copying originals that are longer than max scan width, but shorter than the printer's [media width setting](#). I.e. if you have a printer that prints wider than your scanner can scan, you can still use the full print width when this

setting is enabled.

5. The setting has no effect in situations where the printer (media width) is equal or narrower than the scanner. In these situations the user can manually control copy orientation when loading the scanner as printer output orientation will equal loading orientation.

### ...how do I set printer margins?

1. Select the Setup tab.
2. In the Setup tab, press the Printer button, the Tool button and then the Advanced button. The following dialog is displayed:



3. Select and set the margins for the printer.  
Press OK to save and exit





## HP Pro Scanner

→ [how do I...?](#)

→ [the problem is...](#)

→ [alphabetical index](#)

## how do I collate copies?

The Collate function allows you to group your copies into sets, and then output a selected number of these sets on your printer. All the previewing and enhancement options available for single document copying are also available when using Collate.

For the HP PageWide printer models the collate functionality will work differently. See how to create [collated sets for HP PageWide printers](#).

**NOTE:** The previewing options  will not be available if Batch scan is enabled.



NOTE: The Collate option will only be possible if the number of sets (Copies) are more than one.

### to collate copy - create copy sets

1. Insert the first document of your set into the scanner.
2. Press the Copy tab.
3. Make your copy settings in the Copy tab dialog.

If you wish, you can press the Preview button and make on-screen adjustments and tests.

4. Set the number of sets by pressing the Copies button.  
The number of copies indicates how many sets, each containing all the input originals, will be output on your printer.



5. Press the add page button.  
The original will then be input (captured) as with single-sheet copying, but it will be put on standby inside your system instead of going to the printer.

6. Continue inserting originals that belong to the set and press the add page button  for each one until all the originals that are part of the set have been scanned.

You can adjust each copy in the set just as you can with single document copying.

7. Press the Finish button to activate the whole copy job.



You can cancel the Collate session at any time by pressing the cancel button.



### to create collated sets on HP PageWide printers

1. Insert the first document of your set into the scanner.
2. Press the Copy tab.
3. Make your copy settings in the Copy tab dialog.
4. Set the number of sets by pressing the Copies button.  
The number of copies indicates how many sets, each containing all the input originals, will be output on your printer.



5. Press the add page button.  
The original will then be input (captured) as with single-sheet copying, but it will be put on standby inside your system until the next original is scanned and then it will be send to the printer.
6. Continue inserting originals that belong to the set until all the originals that are part of the set have been scanned.  
You can adjust each page in the set just as you can with single document copying.

**NOTE:** [Batch scan](#) is enabled by default for the HP PageWide printers.

7. Press the Finish button to activate the whole copy job.



You can cancel the Collate session at any time by pressing the cancel button.



Pressing cancel will give you an option to delete last page added or to delete the entire Multipage session.





## HP Pro Scanner

→ [how do I...?](#)

→ [the problem is...](#)

→ [alphabetical index](#)

## how do I manage image files on my system?

Your system's harddisk can at any time contain image files that you will need to access and manage.

### **The source of these files can be:**

- image files saved on the system through the Scan tab.
- image files imported from or on another computer on the network
- image files saved on an an external drive (USB)

### **Actions you may wish to perform on these files can be:**

- Add to List: Add files to the print list from the Print Tab. NOTE that Move/Delete/Rename of files through the file management dialog will not remove them in the print list and will make them unprintable.
- Delete files from your harddisk/system or accessible locations.
- Copy or move files between folders on the system.
- Rename files or create new folders.

All these actions take place through the **File Management dialog**.

The following **files types** can be accessed in the File Management dialog:

- Jpeg, Jpeg 2000, Tiff, Cal, PDF\*.

\* see notes under "[to browse, preview and select files...](#)" and under "[to add files to the print tab's print list](#)"

## to open the file management dialog

There are two ways to reach the file management dialog:

1. Press the Folder button at the bottom of the screen.



2. Press the *Add to List* button in the Print Tab dialog.

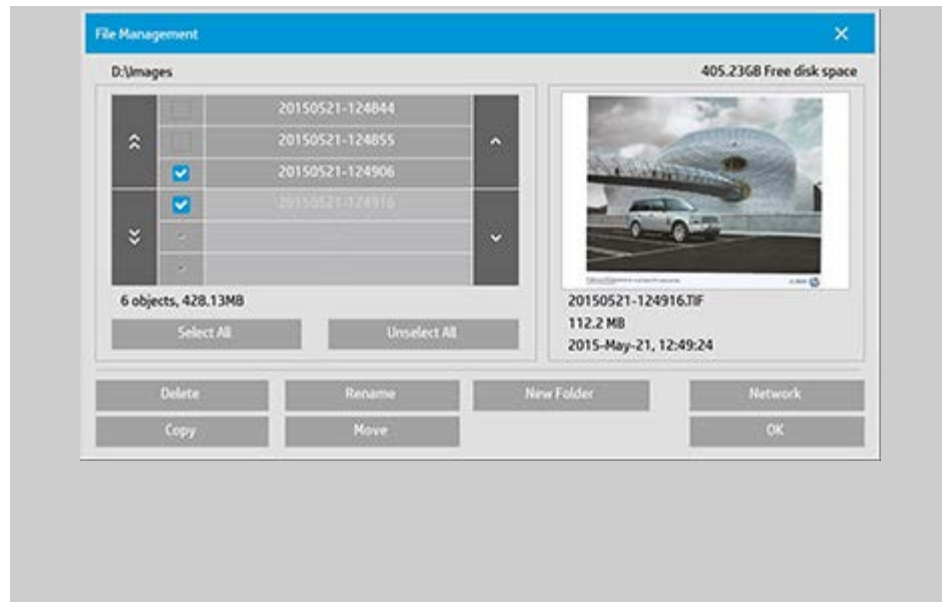

## to browse, preview and select files in the file management dialog

1. The folder up button (marked "..") will move you up a level.

**Local folders:** You can browse to folders on all drives open to the system, including external drives. The C-drive is not open to the system as this is reserved for system files only.

**Network folders:** Per default, the dialog will display only local drives and folders. You can however add network locations to the system. Read the help "[how do I scan to and access a network folder?](#)" for instructions."

2. Clicking on a folder name will move you onto its level.
3. Select files for an action by checking the box to the left of the file name.
4. "Select All" will check the boxes to the left of the all the file names in the current folder being viewed.
5. "Unselect All" will empty the boxes to the left of the all the file names in the current folder being viewed.
6. Click on an image to get a preview and information on the image (name,type,dimensions,file size,creation date).
7. **NOTE:** If inactivity timeout is applied to a network connection then additional logon information could be required to perform the file management operations.  
See more in: [How does the Inactivity timeout for a network connection work?](#)



NOTE about previewing: PDF files can only be previewed if they have a pre-generated thumbnail attached. PDF files created on the system through the Scan tab are always created with a thumbnail while "foreign" imported pdf files may not have a thumbnail.

### to add files to the Print tab's print list

1. Press the Print tab.
2. You can use the Clear List button to start afresh with an empty list.
3. Press the Add to List button to reach the File Management dialog.
4. You select files for addition to the print list by checking the box to the left of the file name.  
**NOTE:** Only printable file formats (not PDF) can be accessed through "Add to List".
5. Use "Select All" and "Unselect All" for multiple selections of files in the current folder.
5. See the instructions under [to browse, preview and select files in the file management dialog](#) above for more instructions on selecting files.
6. See the other instructions on this page regarding file management if you wish to move, copy rename or delete files.
7. Click the OK button to add the checked files to the print list and return to the Print tab. In the Print tab you can see the print list with the files inserted.

NOTE about files in the print list (Print tab): if a file in the print list is moved/deleted/rename through the file management dialog, the file will still be shown in the print list but it can not be printed.

### to delete files from your system

From time to time, you will need to delete scanned files from your accessible folders in order to ensure space for new files. There are two ways to do this:

1. Browse to and select the files you want to delete by checking the box to the left of a file name - See the instructions under [to browse, preview and select files in the file management dialog](#)

above for more instructions on selecting files.

2. Press the Delete button and confirm.

NOTE about files in the print list (Print tab): if a file in the print list is moved/deleted/renamed through the file management dialog, the file will still be shown in the print list but it can not be printed.

### **to Rename files on your system**

1. Browse to and select the files you want to rename by checking the box to the left of a file name - See the instructions under [to browse, preview and select files in the file management dialog](#) above for more instructions on selecting files.
2. Press the Rename button. An edit box with the current file name entered will appear. Edit the name and select OK when done.
3. You can select more than one file at a time. When you select multiple files and then press the Rename button, you will be able to enter a name for each file in turn.

NOTE about files in the print list (Print tab): if a file in the print list is moved/deleted/renamed through the file management dialog, the file will still be shown in the print list but it can not be printed.

### **to Create a new folder on your system**

1. Browse to and select the directory/folder in which you wish to create the new folder - See the instructions under [to browse, preview and select files in the file management dialog](#) above for more instructions on browsing the file system.
2. Press the New Folder button.
3. Enter a name for your new folder in the edit dialog and press OK.
4. The new folder will be inserted as a subfolder to the current directory.

## to copy files to other folders on your system

1. Browse to and select the files you want to copy by checking the box to the left of a file name - See the instructions under [to browse, preview and select files in the file management dialog](#) above for more instructions on selecting files. You can make multiple selections if you intend to copy all the files to the same destination folder.
2. Press the Copy button.
3. The Destination folder dialog will appear. Browse to the destination folder or create a new folder on the system.
4. Press OK to copy the files into the destination folder.

## to move files to other folders on your system

1. Browse to and select the files you want to move by checking the box to the left of a file name - See the instructions under [to browse, preview and select files in the file management dialog](#) above for more instructions on selecting files. You can make multiple selections if you intend to move all the files to the same destination folder.
2. Press the Move button.
4. Press OK to move the files into the destination folder.

NOTE about files in the print list (Print tab): if a file in the print list is moved/deleted/renamed through the file management dialog, the file will still be shown in the print list but it can not be printed.





## HP Pro Scanner

→ [how do I...?](#)

→ [the problem is...](#)

→ [alphabetical index](#)

## how do I save (to file) a duplicate of my copy?

You can tell the system to save duplicates of your copies. While this option is enabled, each time you click the Copy button to start a scan-to-print process, a file containing the same scanned image will be saved on your system.

### to save a duplicate of your copy in a file...

1. Press the Copy tab

2. Press 

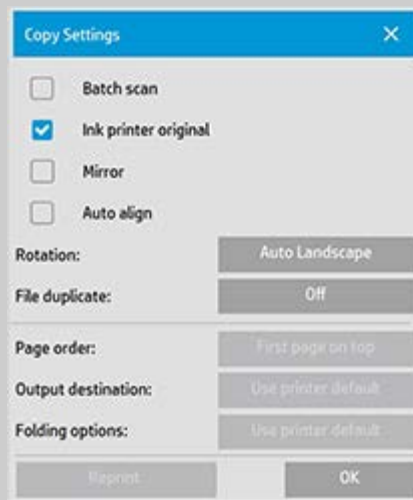

3. Press the File duplicate button.

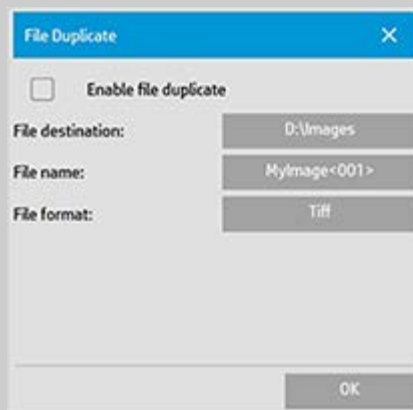

4. Check the "Enable file duplicate" option.

5. Press the *File destination* button if you want to change the place the image file will be saved.
6. Press the *File name* button if you want to specifically name the image file or avoid overwriting existing files. The field contains automatic naming parameters (counter, date, time...) for dynamic creation of new files. You can read more on using automatic file naming parameters [here](#).
7. Press the *File format* button if you want your duplicate in another format.
8. Uncheck the "Enable file duplicate" option when you want to turn the action off.





## HP Pro Scanner

→ [how do I...?](#)

→ [the problem is...](#)



→ [alphabetical index](#)

## how do I enable storage of network connections?

The system can be setup so users can store network connection definitions (username/password pairs) so that these are reestablished every time the system is restarted.

Enabling users to store network connections is an administrator function. If the [Administrator password has been setup and activated](#), you will be prompted to enter it before you can apply this function.

### to enable storage of network connections ...

1. Press Setup Tab > 
2. Select System
3. Press the Advanced button.
4. Enter the Administrator password if prompted by the system.
5. Press the Security Setup button.
6. Press the Store Network Connections button.
7. Select the "Store network connection" option box and press OK.
8. With the "Store network connection" option box selected, the system will then **make visible** (otherwise hidden) a "Reconnect at logon" option on the dialog. To access the option:  
Select Folder button  > Network > Add Network Connections. The dialog and the "Reconnect at logon" option with network connections is described in the topic [how do I scan to and access a network folder?](#)
9. Stored connections that fail (for example due to changes on the network) can be removed manually through the Folder button - > Network -> "Remove Network Connection".

**NOTE:** Storing usernames and passwords on the system can pose security risks.





## HP Pro Scanner

→ [how do I...?](#)

→ [the problem is...](#)

→ [alphabetical index](#)

## how do I create and retrieve data files for support and debugging?

Your system contains functions for creating data files that can be helpful for debugging errors. In a typical case, these files can be created by users who then send them to their support service for debugging.

To access the varrious dubugging file creation options:

Setup tab >  > System > Advanced > Troubleshooting

*SCANdump:* You can create data files for debugging **problems with the scanner** device through the *SCANdump option*.

*Print to File:* You can help debuggng of **print output problems** by redirecting your print output data to a file with the *Print to File* option.

*Print Screen:* You can also save the **image of your screen** for conveying the user inteferface settings or error messages by using the *Print Screen* button.

*Export Log Files:* **For retrieving the data files for support and debugging.** After using the options above, the debugging output files will reside in a protected area and must be exported in order for you to access them. Press the **Export Log Files** button to export the files to your D:\Images folder or USB drive.

### to create scanner a data file (scandump) ...

1. Press Setup Tab >  > System > Advanced
2. Enter the Administrator password if prompted by the system.
3. Press the Troubleshooting button.
4. Press the *SCANdump* button. This starts the SCANdump program.
5. The SCANdump program creates a data file scandump.con that contains light profile data, error logs and statistics about the scanner's activity.
6. Press the **Export Log Files** button to export the files to your D:\Images folder or to a USB drive.



7. If you choose to export to the D:\Images folder and need to move the files to another computer for processing/sending: The panel PC's D:\Images folder can be accessed from other computers through its IP. See "[how do I access shared files from another computer](#)" for instructions.

### to create a print output data file ...

1. Press Setup Tab >  > System > Advanced
2. Enter the Administrator password if prompted by the system.
3. Press the Troubleshooting button.
4. Press the *Print to File* button. This tells the program to send printer data to a file rather than to the printer the when you print.
5. Printer data is saved to the file D:\Images\print.prn.
6. You may need to move the file print.prn to another computer for processing/sending: The panel PC's D:\Images folder can be accessed from other computers through its IP. See "[how do I access shared files from another computer](#)" for instructions.

### to create a screen image file ...

1. Press Setup Tab >  > System > Advanced
2. Enter the Administrator password if prompted by the system.
3. Press the Troubleshooting button.
4. Press the *Print Screen* button.
5. You can activate a PrnScn button on the upper corner of you screen, to make continious scren snapshots.
6. Screen images are saved to the folder D:\Images\
7. You may need to move the files to another computer for processing/sending: The panel PC's D:\Images folder can be accessed from other computers through its IP. See "[how do I access shared files from another computer](#)" for instructions.



→ [printing instructions](#)

→ [legal information](#)

© Copyright 2012, 2015 HP Development Company, L.P



## HP Pro Scanner

→ [how do I...?](#)

→ [the problem is...](#)

→ [alphabetical index](#)

## how do I scan to email?

When scanning to file (File tab), you can tell the system to create your scan as an attachment in an email (scan-to-email).

Before using the scan to email functionality, you must [setup your outgoing email information](#) in the system.

### To scan to email

1. Select the Scan tab .
2. Make your scan settings.
3. Select the *File destination* button
4. Select the Email option.

The screenshot shows a dialog box titled "File Destination" with a close button (X) in the top right corner. Inside the dialog, there are two radio buttons: "Folder" (unselected) and "Email" (selected). Below the radio buttons, there are three text input fields labeled "Address:", "Subject:", and "Message:". An "OK" button is located at the bottom right of the dialog.

5. Fill in the destination email address, the Subject line and your message to the email recipient.
6. Press OK to apply.

### To set up outgoing email

To enable use of scan-to-email, you need to setup your outgoing email account.

1. Press the Setup tab .
2. Select  > System > Advanced.
3. Press the Email Setup button.

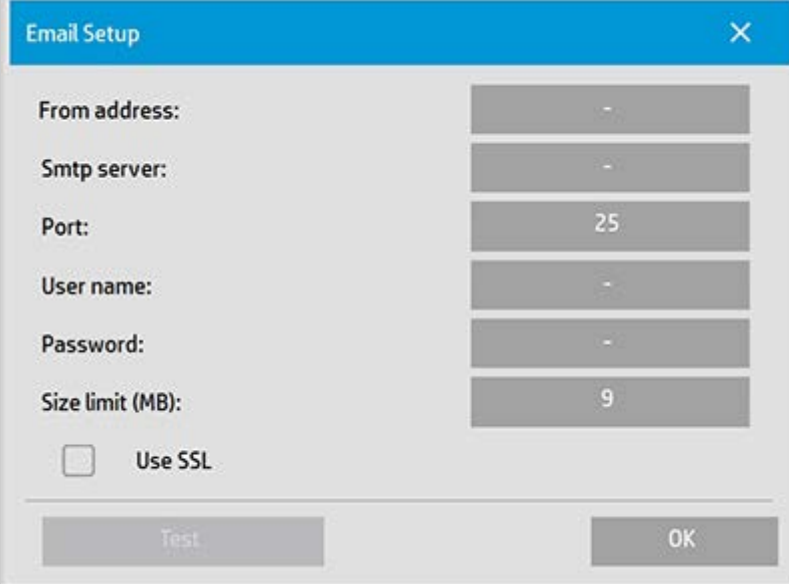

The image shows a dialog box titled "Email Setup" with a close button (X) in the top right corner. The dialog contains several input fields and a checkbox. The fields are: "From address:" with a dash (-) in the input box; "Smtp server:" with a dash (-) in the input box; "Port:" with the number 25 in the input box; "User name:" with a dash (-) in the input box; "Password:" with a dash (-) in the input box; and "Size limit (MB):" with the number 9 in the input box. Below these fields is a checkbox labeled "Use SSL" which is currently unchecked. At the bottom of the dialog, there are two buttons: "Test" on the left and "OK" on the right.

4. Enter your email account information.
5. Press the Test button to verify your settings.

**NOTE:** Contact your system administrator if in doubt about one of more of the settings.





## HP Pro Scanner

→ [how do I...?](#)

→ [the problem is...](#)

→ [alphabetical index](#)

## how do I scan multiple pages into a single file ?

The Multipage Scan function allows you to combine 2 or more scans into a single PDF file. All the image settings, previewing and enhancement options that are available for single document scanning are also available when using Multipage.

You must set the scan file's **Format** to PDF Multipage in order to enable Multipage Scan.

### To combine multiple pages into a single PDF file

1. Insert the first document of your set into the scanner.
2. Press the Scan tab.
3. Make your Scan settings in the Scan tab dialog and set your destination folder.
4. Press the File name button to set the file name.
5. Press the **File Format button and select PDF Multipage** as the file format.

6. Press the add page button . The original will then be input (captured) as with single-sheet scanning, but it will be put on standby inside your system instead of being saved to the file and destination folder.

7. Continue inserting originals that belong to the set and press the add page button  for each one until all the originals that are part of the multipage file have been scanned.

You can adjust settings before each scan in the multipage file just as you can with single document scanning.

7. Press the Save scan button to save the job.



NOTE: You can press the cancel button  at any time during the Multipage session.

Pressing cancel will give you an option to delete last page added or to delete the entire Multipage session.



→ [printing instructions](#)

→ [legal information](#)

© Copyright 2012, 2015 HP Development Company, L.P



## HP Pro Scanner

→ [how do I...?](#)

→ [the problem is...](#)

→ [alphabetical index](#)

## how to rotate the output 90 degrees?

The "90° Right" option is useful when you want your copy output to be rotated 90 degrees to the right. This is useful if e.g. a folding machine requires a rotated output.

NOTE: The process of rotating the image is time and resource consuming. Therefore, use this option only when you are forced to have a 90 degree rotation of the output.

## ...rotate of the output 90 dregrees?

1. Select the Copy tab.
2. In the Copy tab, press  and the following dialog is displayed:

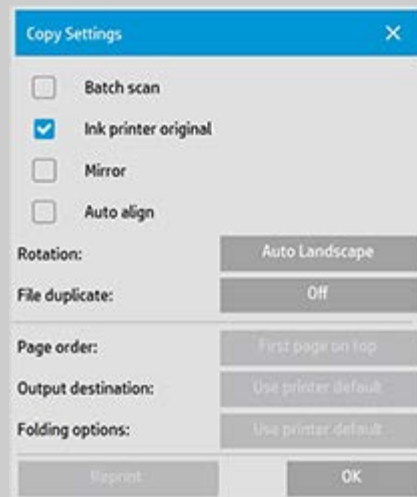

3. Press the Rotation button and select "90° Right"  
Press OK to save and exit
4. When 90° Right is active it force the scanned input to be output with a rotation of 90 degrees to the right..



→ [printing instructions](#)

→ [legal information](#)

© Copyright 2012, 2015 HP Development Company, L.P





## HP Pro Scanner

→ [how do I...?](#)

→ [the problem is...](#)

→ [alphabetical index](#)

## how to set the different output options?

The output options are useful when you want to control your printed copies with advanced options.

**NOTE:** The availability of the output options depends on the printer model installed on the system.

## ...set page order?

1. Select the Copy tab.
2. In the Copy tab, press  and the following dialog is displayed:

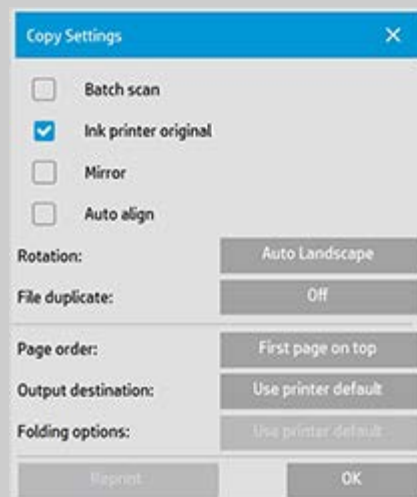

3. Press the Page order button and select in which order the output should be printed.

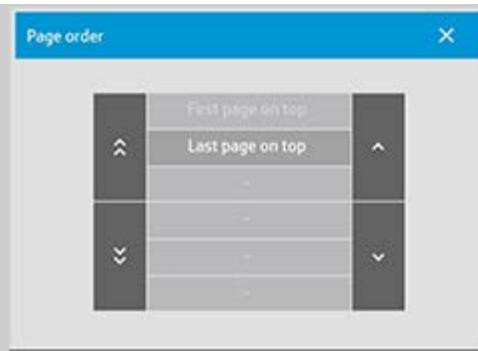

**NOTE:** The availability of the Page order option depends on the printer model installed on the system.

## ...set output destination?

1. Select the Copy tab.
2. In the Copy tab, press  and the following dialog is displayed:

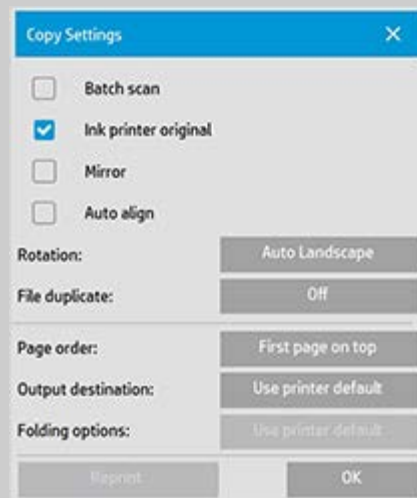

3. Press the Output destination button and select which destination should be use.

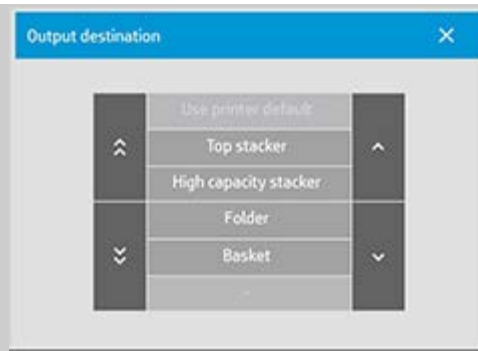

**NOTE:** The availability of the Output destination option depends on the printer model installed on the system.

## ...set folding options?

1. Select the Copy tab.
2. In the Copy tab, press  and the following dialog is displayed:

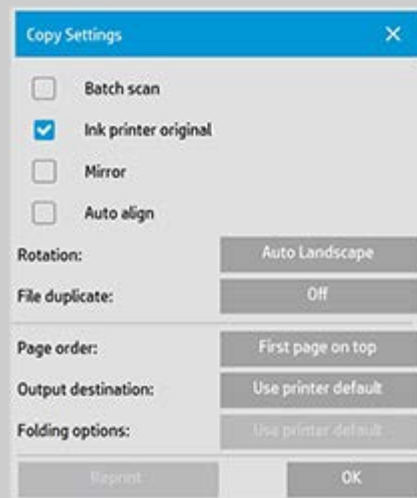

3. Press the Output destination and select "Folder".  
When selected as Output destination then the "Folding options" button will become available.



4. Press the Folding options button and select which folding type should be used.



**NOTE:** The availability of the Folding option depends on the printer model installed on the system.



[→ printing instructions](#)

[→ legal information](#)

© Copyright 2012, 2015 HP Development Company, L.P



## HP Pro Scanner

→ [how do I...?](#)

→ [the problem is...](#)

→ [alphabetical index](#)

## how to disable USB set the different output options?

The disable USB storage is useful when you want to prevent scanning to USB connected storage devices.

### ...disable USB storage?

1. Press Setup Tab > 
2. Select System
3. Press the Advanced button.
4. Enter the Administrator password if prompted by the system.
5. Press the Security Setup button.
6. Press the Disable USB Storage button.
7. Select the "Disable USB Storage" option box and press OK.
8. With the "Disable USB Storage" option box selected, the system will not show attached USB storage devices when using the [File Management](#) or [File Destination](#).





## HP Pro Scanner

→ [how do I...?](#)

→ [the problem is...](#)

→ [alphabetical index](#)

## how to set default settings?

The change of default settings can be useful when you want to use the same settings for a period of time used.

The reset button  will then restore the saved default settings.

### ...save current settings as new defaults?

1. Press Setup Tab > 
2. Select System
3. Press the Advanced button.
4. Enter the Administrator password if prompted by the system.
5. Press the Default Settings button.
6. Press the Save Current Settings button.

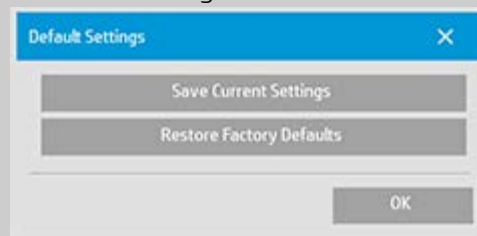

7. Confirm Yes/No if settings should be saved or not.

### ...restore factory defaults?

1. Press Setup Tab > 

2. Select System

3. Press the Advanced button.
4. Enter the Administrator password if prompted by the system.
5. Press the Default Settings button.
6. Press the Restore Factory Defaults button.

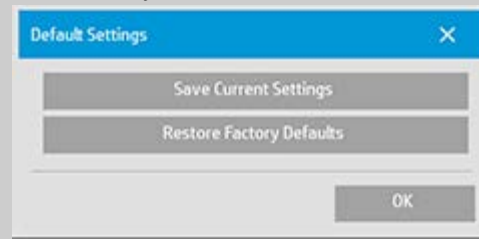

7. Confirm Yes/No if factory defaults should be restored or not.

&nbsp;



[printing instructions](#)

[legal information](#)

© Copyright 2012, 2015 HP Development Company, L.P