

⚠ CAUTION:

If toner gets on clothing, wipe it off by using a dry cloth and wash the clothes in cold water. Hot water sets toner into fabric.

🔔 NOTE:

Information about recycling used toner cartridges is on the toner cartridge box.

1. Press the cartridge door release button to open the door.

Figure 1: Open the cartridge door

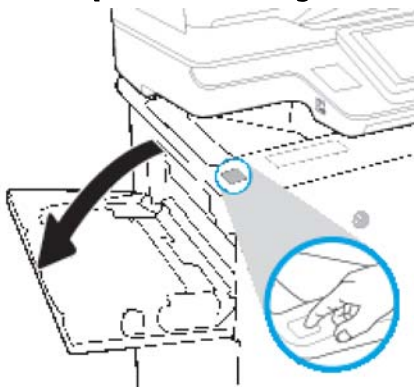

2. Pull out the cartridge drawer.

Figure 2: Open the toner cartridge drawer

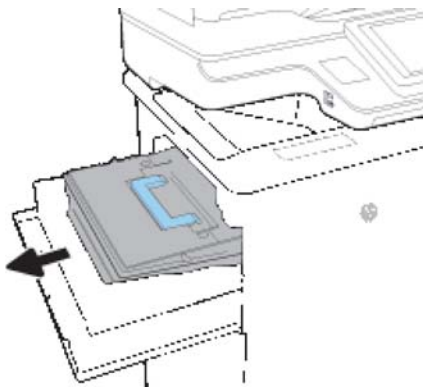

3. Grasp the handle or indentation of the used toner cartridge and pull up to remove it.

Figure 3: Remove the toner cartridge

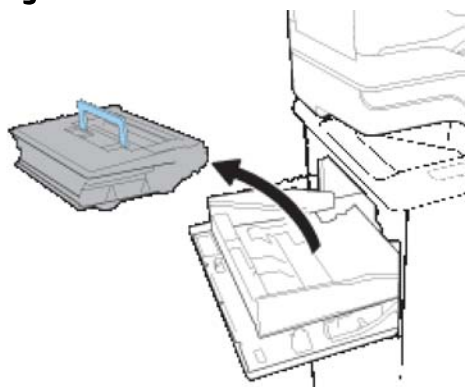

4. Remove the new toner cartridge from its protective bag.

Figure 4: New toner cartridge

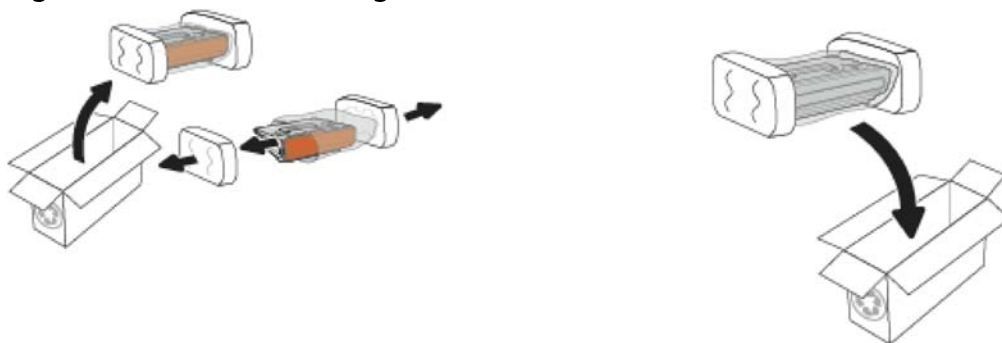

5. Hold both ends of the toner cartridge and rock it 5-6 times.

Figure 5: Rock the toner cartridge

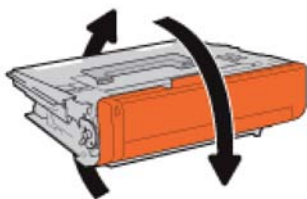

6. Remove the cartridge shipping cover.

Figure 6: Remove the shipping cover

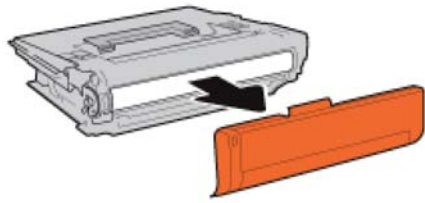

7. Place the toner cartridge in the cartridge drawer.

Figure 7: Install the toner cartridge

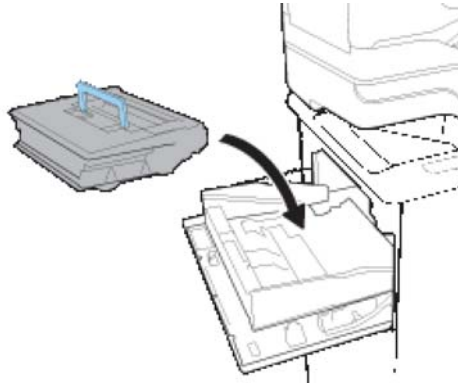

8. Close the toner cartridge drawer.

Figure 8: Close the toner cartridge drawer

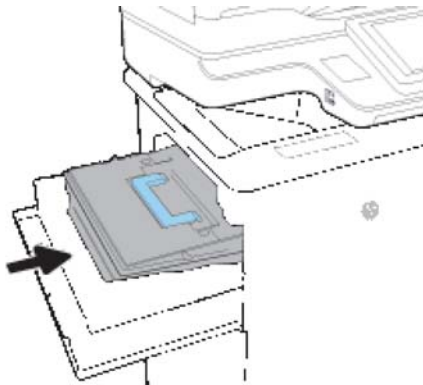

9. Close the cartridge door.

Figure 9: Close the cartridge door

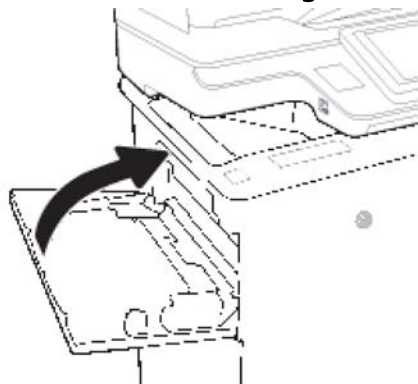

10. Pack the used toner cartridge into the box that the new cartridge came in. Adhere the prepaid shipping label to the box, and return the used cartridge to HP for recycling.

Figure 10: Recycle the used cartridge

