



Color LaserJet Managed MFP E87640, E87650, E87660

How to replace a toner cartridge

The printer Supplies Status Page indicates when a toner cartridge level is low. The actual cartridge life remaining can vary. The cartridge does not need to be replaced at this time. Consider having a replacement cartridge available to install when print quality is no longer acceptable.

Table 1 Toner cartridge information

Item	Part number
HP Black Managed LJ Toner Cartridge	W9050MC
HP Cyan Managed LJ Toner Cartridge	W9051MC
HP Yellow Managed LJ Toner Cartridge	W9052MC
HP Magenta Managed LJ Toner Cartridge	W9053MC

Do not remove the cartridge from its package until you are ready to use it.

 **NOTE:** Information about recycling used toner cartridges is included on the cartridge box and in the recycling guide inside the box.

1. Open the front door of the printer.

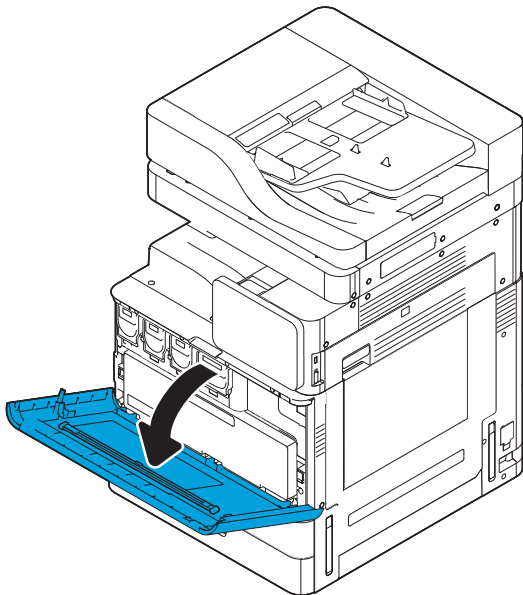

2. Grasp the end of the used cartridge and pull it straight out to remove it.

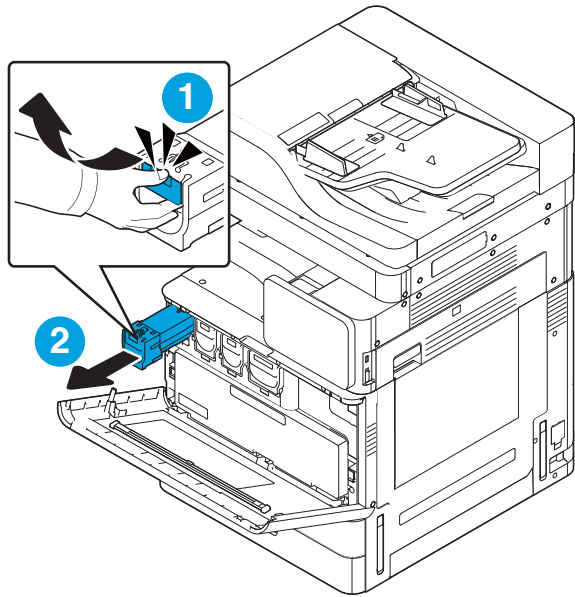

3. Remove the new cartridge from the packaging.

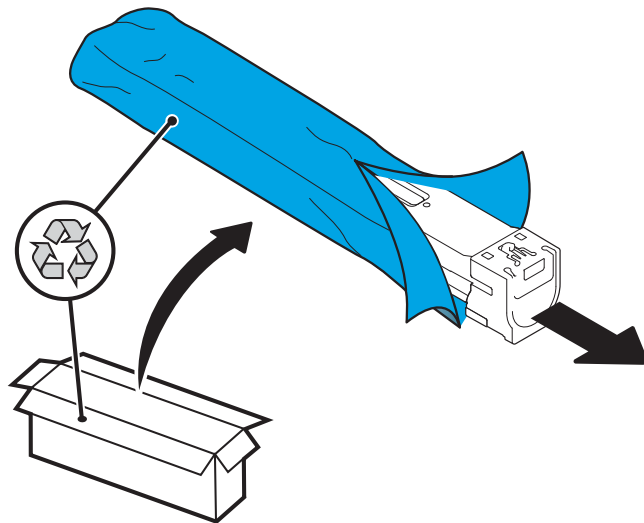

 **NOTE:** Save all packaging for recycling the used cartridge.

4. Rotate the end cap counterclockwise until the end cap releases from the end of the cartridge. Discard the end cap.

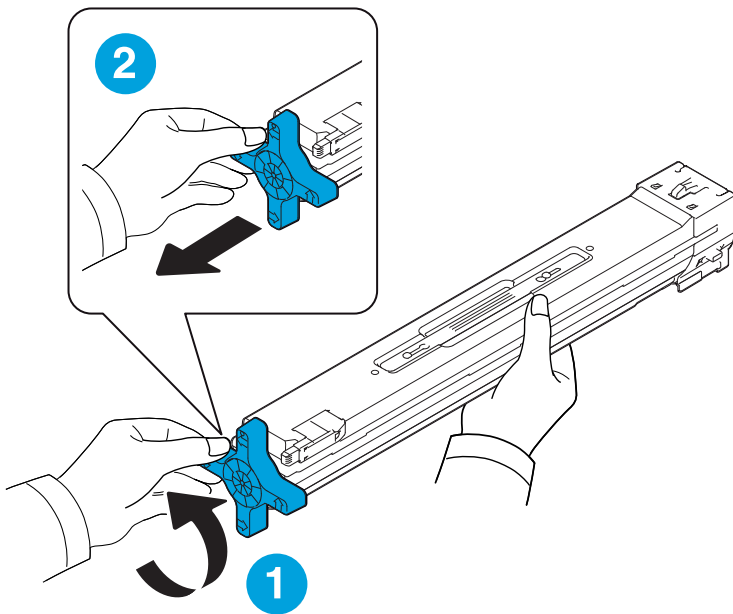

5. Hold both ends of the cartridge and rock it 5 or 6 times to evenly distribute the toner that is inside.

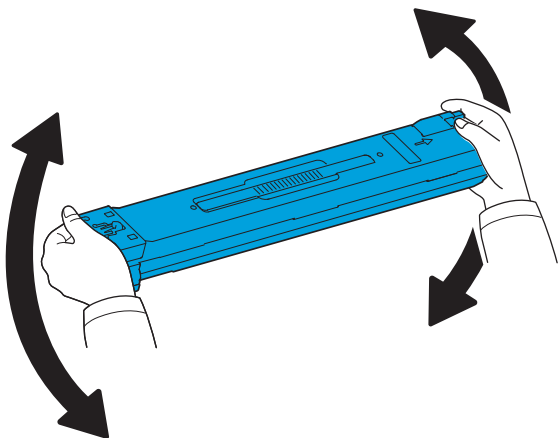

⚠ CAUTION: If toner gets on clothing, wipe it off by using a dry cloth and wash the clothes in cold water. Hot water sets toner into fabric.

6. Hold the cartridge and align it with the corresponding slot inside the printer. Insert the cartridge into its slot until it locks in place.

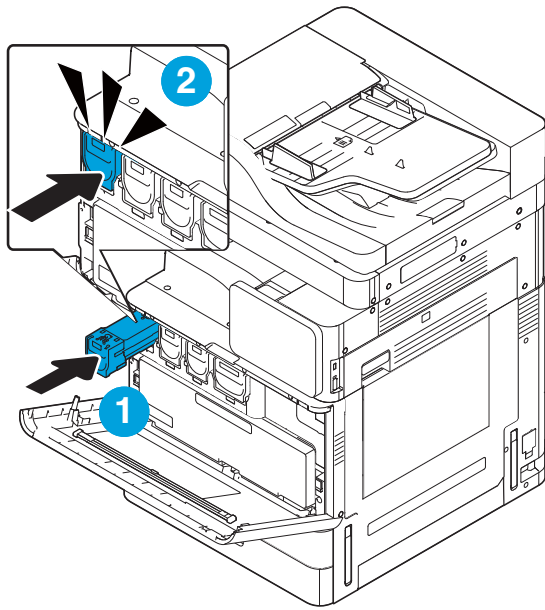

7. Close the front door.

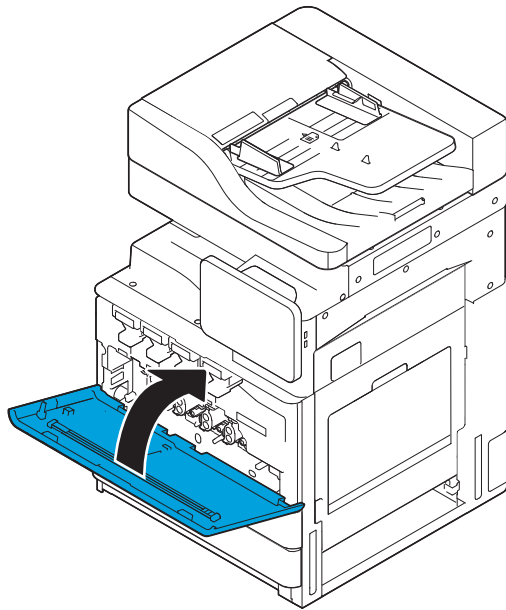

 **NOTE:** If the front door is not closed completely, the printer will not operate.